



Simpler, Faster, Better

ECO-BLOCK ENGINEERS & DESIGNERS MANUAL

All tables & drawings are specific to the ECO-Block insulated cold form system only and not to be applied to any other similar products.

Should there be any questions about the content or design theory within, these are to be directed to ECO-Block Australia or alternatively, Newport Consulting Engineers. Contact details can be found in the rear of the manual.





Simpler, Faster, Better

Table of Contents

1.0 - General.....	2
1.1 - Sources.....	2
1.2 – Application	2
1.3 – Materials	3
1.4 – Joints	3
1.5 – Other Loads	4
1.6 – Standard Structural Details & Connections	5
2.0 – Simplified Design of ECO-Block Walls	10
3.0 – Detailed Design of ECO-Block Frame	17
Solid Wall Framing	18
Wall Framing Adjacent to Opening.....	19
Lintels – Uplift	20
Lintels –Downwards Load Combination	28
Lintels – Supporting Floors.....	37
4.0 – Wall Bracing	43
4.1 – Applied Raking Forces	43
4.2 – Bracing Wall Capacities	44
Bracing Wall Capacities – In Plane	44
Bracing Wall Capacities – Out of Plane	46
4.3 – Further Design Considerations for Bracing Walls	52
5.0 Basement Walls & Retaining Walls	53
5.1 – Waterproofing & Drainage.....	53
5.2 – Standard Retaining Walls	53
6.0 – Tie Down	70
6.1 – Other Roof Connections.....	73
7.0 – Wall Finishing	75
7.1 – Render	75
7.2 – Plasterboard, Hardboard & Metal Sheet	75
7.3 – Timber Cladding	75
7.4 – Fixing of Windows	75
8.0 – References.....	76

Manual written & prepared by Des Newport Consulting Engineers – 2010



Simpler, Faster, Better

1.0 - General

This manual is intended as a designer's tool for residential housing from ECO-Block insulated concrete form systems. It has been prepared by the supplier in conjunction with Des Newport Consulting Engineers. The contents contained herewith shall provide accurate design outcomes for houses in various locations and under multiple wind ratings. This manual is to be used in combination with AS1684.2 & 3 2010 (Sections 8 & 9) for complete design of residential houses.

1.1 - Sources

Calculations in this manual are within the scope of residential low rise structures, although the same design theory provided herein may be applied to other types of structures.

The following tabulated calculations and detailed drawings are designed and developed in accordance with *AS1684.2 & 3 (2010) Residential Timber Framed Construction for Non-Cyclonic & Cyclonic Areas* respectively; *AS3600 (2001) Concrete Structures*; & *AS3700 (2001) Masonry Structures*. Other standards used in calculations are *AS1170.0 & 1 (2002) Structural Design Actions*, & *AS4678 Earth Retaining Structures*.

In compliance with the Building Code of Australia, the relevant technical standard used for design in this manual, as a directive and comparative guide is AS3700 Masonry Structures. This is because the recommended spacing of reinforcement bars, though approved through research and testing, does not comply with the recommendations set out in AS3600 Concrete Structures.

1.2 - Application

The design and calculations supplied in the manual assume:

- The footings are properly constructed in accordance with AS2870 Residential Slabs & Footings or an appropriate technical guide.
- The structural action of reinforcing bars within the concrete core carries bending & shear stresses along their length to supports. Vertical bars transfer lateral loads to ground & horizontal bars distribute the loads evenly along the wall.
- Floors or roof structures adjacent to the ECO-Block wall will act as a lateral support for the wall, transferring load throughout the structure & to any specific bracing measures within the building to resist lateral loads.
- Interaction of the bond beam steel reinforcement & concrete in the wall will resist the shear & tension stresses induced in the wall by uplift forces acting on a roof structure the ECO-Block wall is supporting. These forces are transferred from the roof to the wall by tie down connections.
- Lateral loads on openings in the wall are fully transferred through the edges of the opening to the ECO-Block wall. Reinforcing at the edges of the opening resists the induced bending stresses & carries these forces to foundations or bracing systems.
- Lintels are to be designed in accordance with AS3600 Concrete Structures, given that the beam depth is within the limit set in that standard and adequate reinforcing is specified to comply with the standard.

1.3 – Materials

Polystyrene: nominally 64mm closed cell polystyrene panels each side of wall.

Polystyrene side panels are the permanent formwork & finished thermal insulation. These are manufactured to AS1366.3 (1992) Rigid Cellular Plastics Sheets for Thermal Insulation – Rigid cellular Polystyrene (Moulded).

Concrete: 20MPa
150mm slump
10mm maximum aggregate size

Concrete for filling the wall is to be placed by tremmie & vibrated to minimum typical construction effort with a pencil vibrator. It is important to note that while 20MPa does not seem like a suitable strength mix, the impervious formwork ensures ongoing optimum curing conditions for the concrete infill resulting in minimum drying shrinkage & increased long term characteristic compressive strength. The concrete is placed in 3 block (or 1200mm high) lifts. The concrete needs to sufficiently harden and set before the forms are filled any higher.

Steel: D500N grade bar
fy= 500MPa
Lap = 600mm for 12mm diameter bars
Lap =800mm for 16mm diameter bars

Steel to be placed in concrete in accordance with AS3600 (2001) Concrete Structures.

1.4 – Joints

The ECO-Block walling system does not require articulation joints when applied to most residential structures. The requirements for control joints (which are applicable to masonry facades & walls) prevent significant cracks or openings in order to control water ingress and the visual appeal of the finished surface. The polystyrene interlocking panels of the ECO-Block wall prevent water ingress and covers any shrinkage strain induced cracking of the concrete surface.

As a result of not needing articulation joints in the walls, there are a number of design considerations to remember when applying the system.

1. The walls shall be treated as a rigid structure and the slab footings shall be sized accordingly to accommodate this.
2. Single lengths of flat wall greater than 20m should be re-evaluated for the effect of shrinkage strain as per AS3600.
3. If the wall is of significant length and to be used in fire applications, the extent of shrinkage cracking is to be reviewed as per AS3600
4. Lintel beams are controlled for cracking as per AS3600



Simpler, Faster, Better

1.5 – Other Loads

Where other loads not covered in AS1170.0-2 are applied to ECO-Block walls, designer is to treat structure as either concrete or reinforced masonry using the relevant standard for calculations.

1170.4 Earthquake Actions

When designing for lateral earthquake loads, the designer is to use AS1170.4 (2007) Earthquake Actions. Unless the structure is heavily reinforced such that steel spacing complies with AS3600 concrete structures, the following values are to be used when calculating the base shear force in accordance with clause 6.2.

$S_p = 0.77$ – Performance Factor

$\mu = 1.5$ – Ductility Factor

$k_t = 0.05$ - Frame Type Coefficient for determining Natural Period

1.6 – Standard Structural Details & Connections

The following are general structural details and common connections for the ECO-Block system when used in smaller residential buildings & single unit dwellings.

Reinforcement is made up of vertical & horizontal bars & ligatures if required in lintels.

There should be a minimum of three horizontal bars from top to bottom of wall: the bond beam, the bottom bar, and one at mid height. Horizontal bars should also be placed on the underside of window openings as a sill beam.

Vertical reinforcing is to be specified as per the diagrams or tables provided.

Ligatures are to be specified as per figure 1.6g

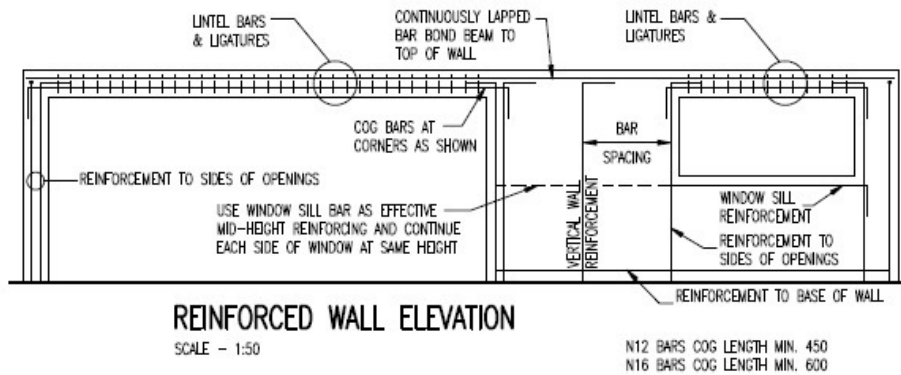

Fig 1.6a General Wall Reinforcing Layout

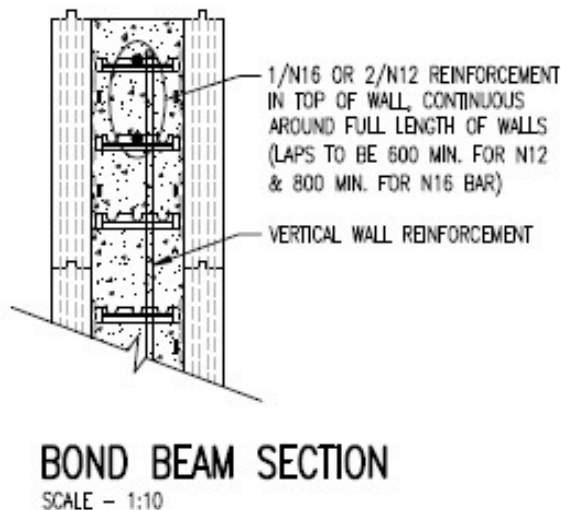
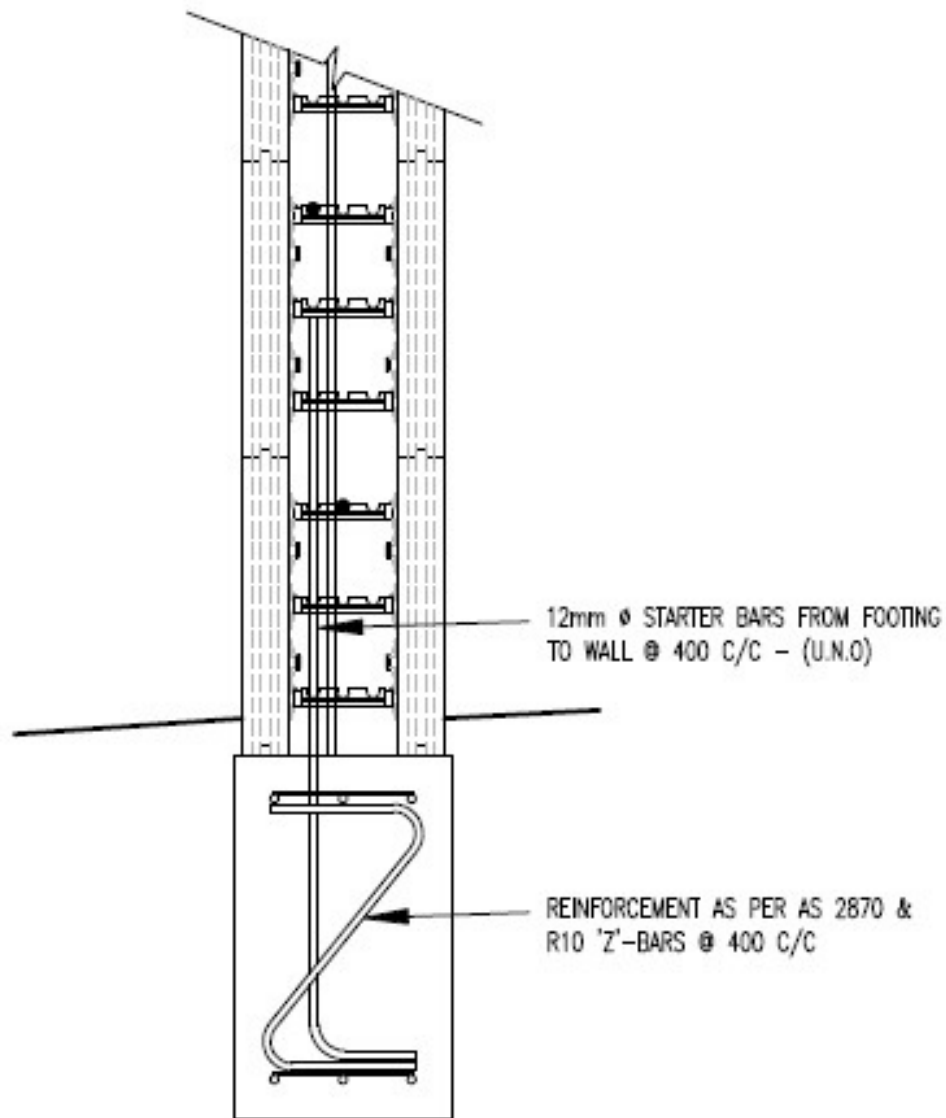

Fig 1.6b Typical Bond Beam Detail



NOTE: FOOTING DESIGN TO BE DONE IN ACCORDANCE WITH AS2870 RESIDENTIAL SLABS & FOOTINGS. WHERE ECO-BLOCK 330 SERIES IS USED, WIDEN FOOTING TO 350 AS PER STANDARD. ECO-BLOCK WALL IS TO BE TREATED AS SINGLE LEAF & REINFORCED OR FULL/ARTICULATED FULL MASONRY

FOOTINGS

SCALE - 1:10

Fig 1.6c Typical Strip Footing Detail (ECO-Block on slab edge beam detail similar)

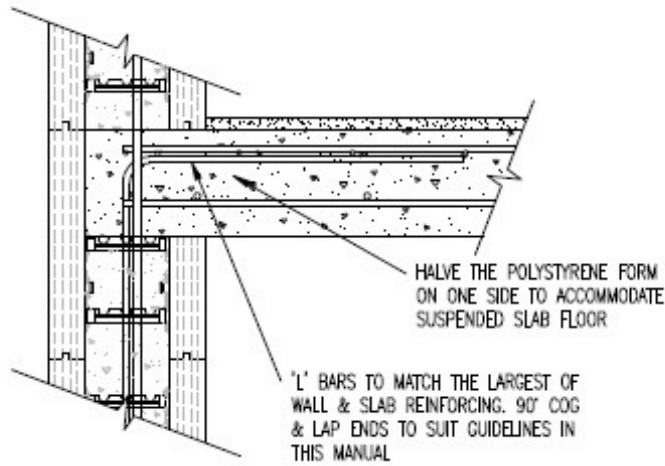

CONCRETE FLOOR SLAB TO WALL

SCALE - 1:10

Fig 1.6d Concrete Suspended Slab to ECO-Block Wall Detail

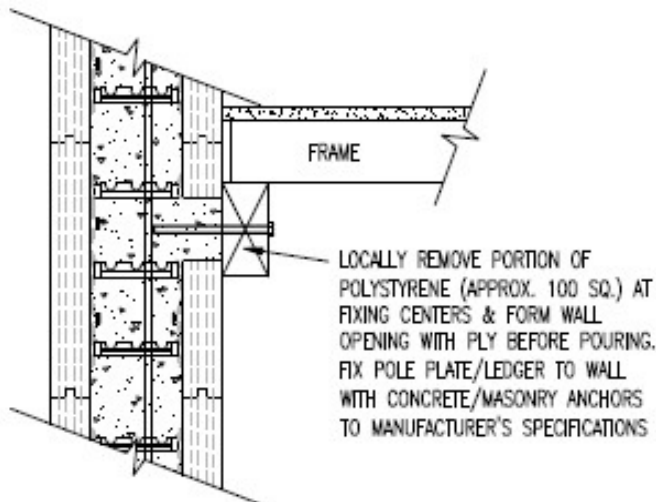

NOTE: THIS IS APPLICABLE TO 230 & 280 SERIES WALLS TO PROVIDE FOR FASTENER LENGTH & TO ALL ECO-BLOCK WALL SYSTEMS FOR HIGH POINT LOAD CONNECTIONS

TIMBER FLOOR/ROOF FRAME TO WALL

SCALE - 1:10

Fig 1.6e Timber Framed Floor or Roof to ECO-Block Wall Detail (Connections for steel frame similar)

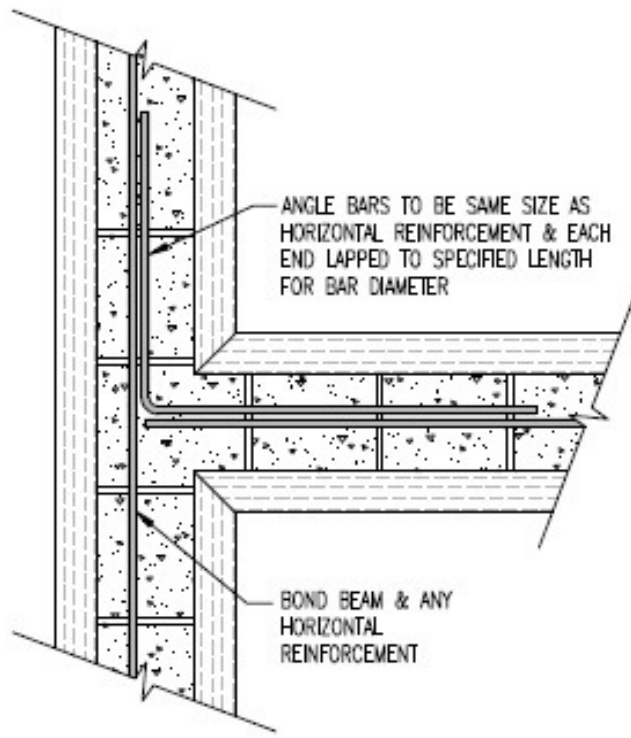

WALL T-INTERSECTION

SCALE - 1:10

Fig 1.6f Internal ECO-Block Wall to External ECO-Block Wall (Also use for bracing walls)

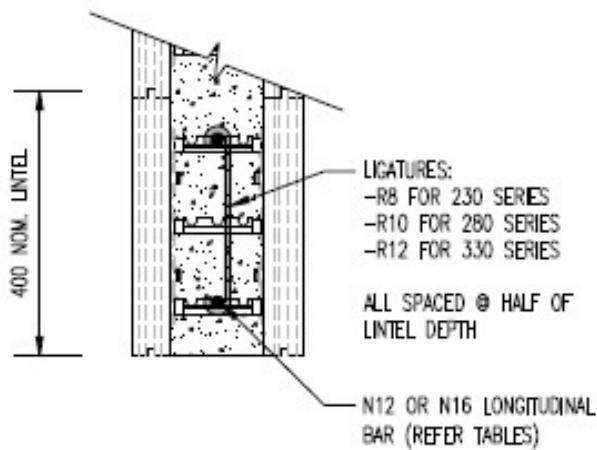

LINTEL SECTION

SCALE - 1:10

Fig 1.6g Typical Lintel Section

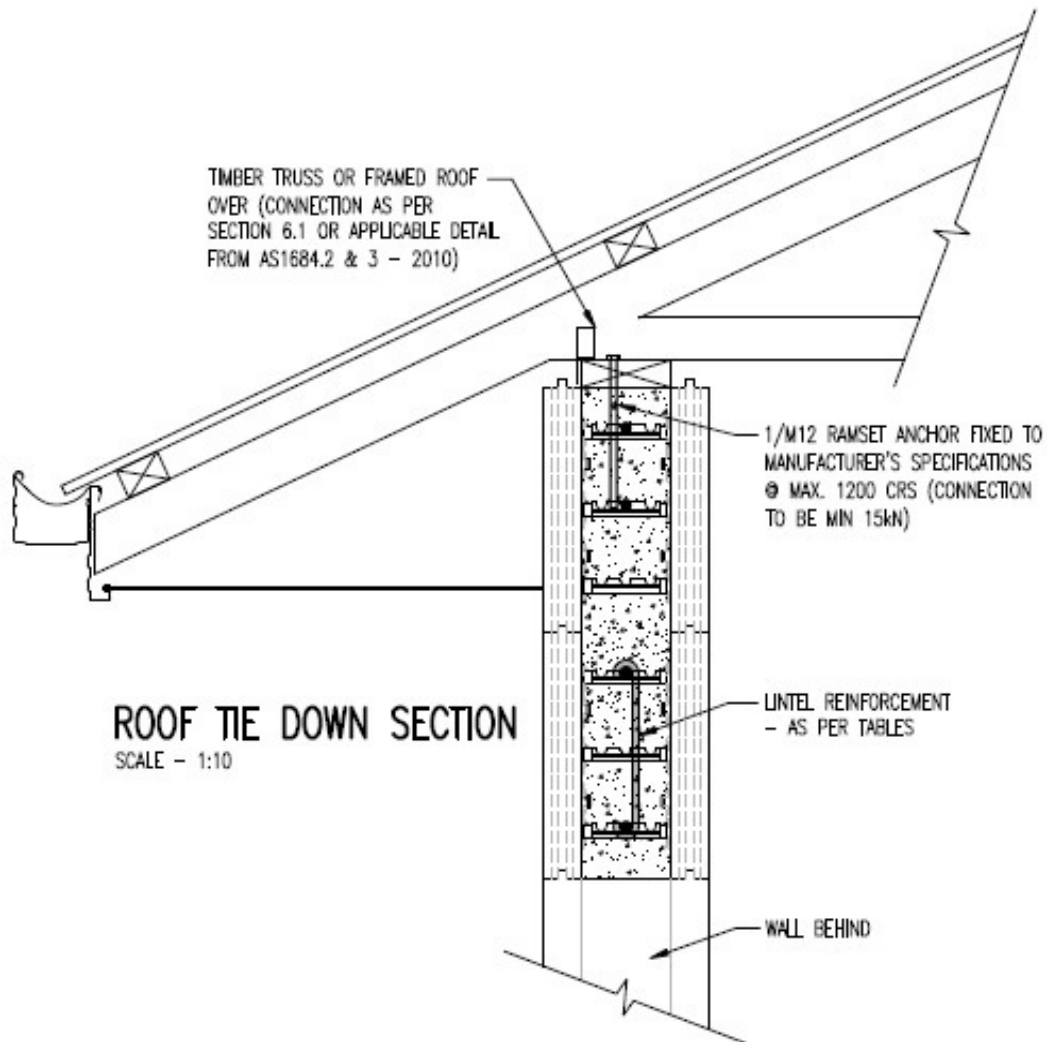

Fig 1.6h Standard Truss Roof Connection Details

2.0 – Simplified Design of ECO-Block Walls

The following drawings may be used as a means of quick design for common scenarios in residential houses. These drawings assume a maximum building width or roof load width (refer figure 1.1 of AS1684.2-3) of no greater than 10 metres unless otherwise noted.

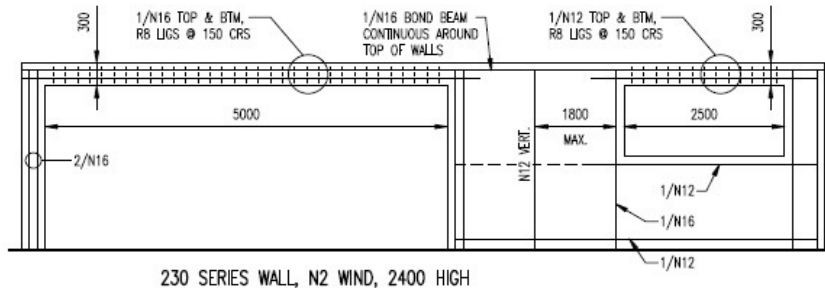

Fig 2a: 2400 High Wall, N2 Wind Rating, 230 Series ECO-Block (Max. roof load width: 5.2m)

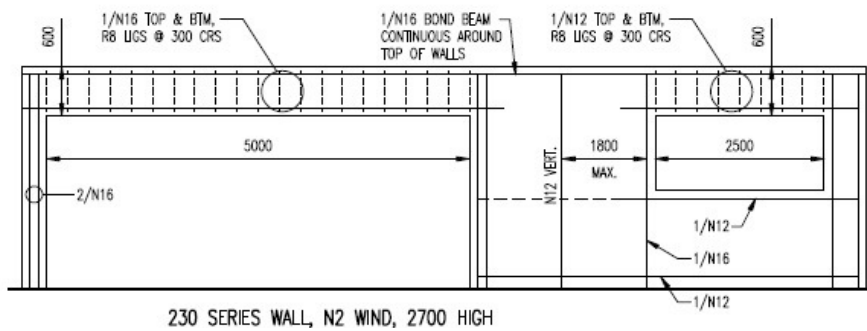

Fig 2b: 2700 High Wall, N2 Wind Rating, 230 Series ECO-Block (Max. roof load width: 10.0m)

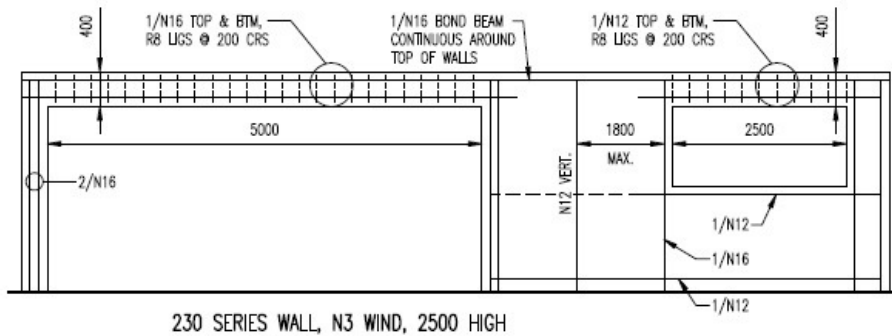
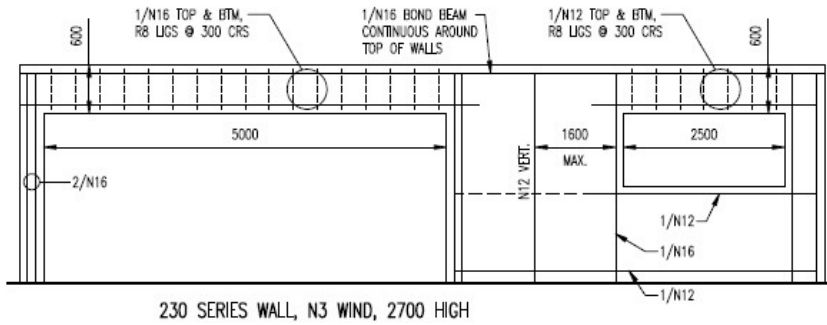
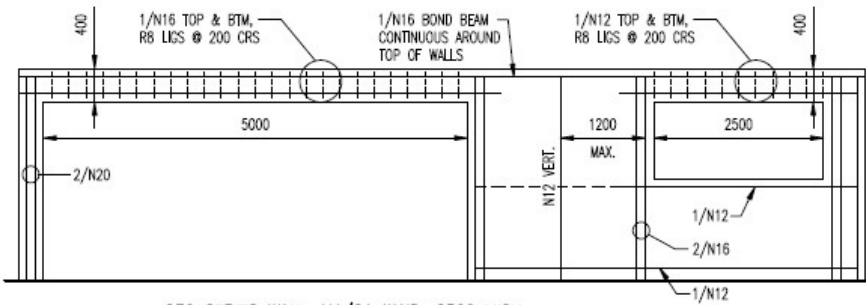

Fig 2c: 2500 High Wall, N3 Wind Rating, 230 Series ECO-Block (Max. roof load width: 6.6m)



230 SERIES WALL, N3 WIND, 2700 HIGH

Fig 2d: 2700 High Wall, N3 Wind Rating, 230 Series ECO-Block (Max. roof load width: 10.0m)



230 SERIES WALL, N4/C1 WIND, 2500 HIGH

Fig 2e: 2500 High Wall, N4/C1 Wind Rating, 230 Series ECO-Block (Max. roof load width: 5.2m)

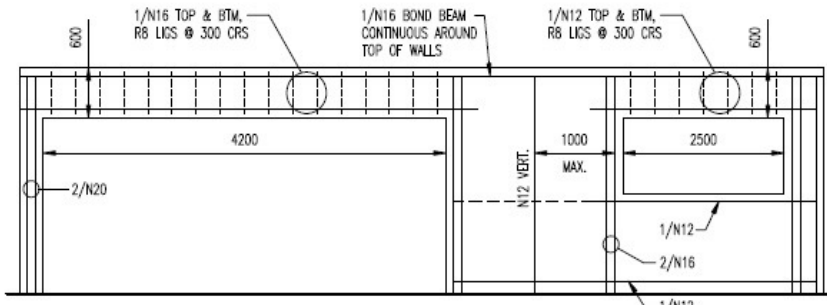

230 SERIES WALL, N4/C1 WIND, 2700 HIGH

Fig 2f: 2700 High Wall, N4/C1 Wind Rating, 230 Series ECO-Block (Max. roof load width: 9.0m)

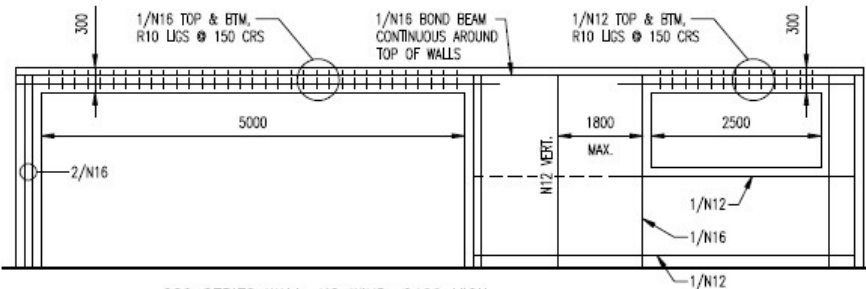

280 SERIES WALL, N2 WIND, 2400 HIGH

Fig 2g: 2400 High Wall, N2 Wind Rating, 280 Series ECO-Block (Max. roof load width: 5.6m)

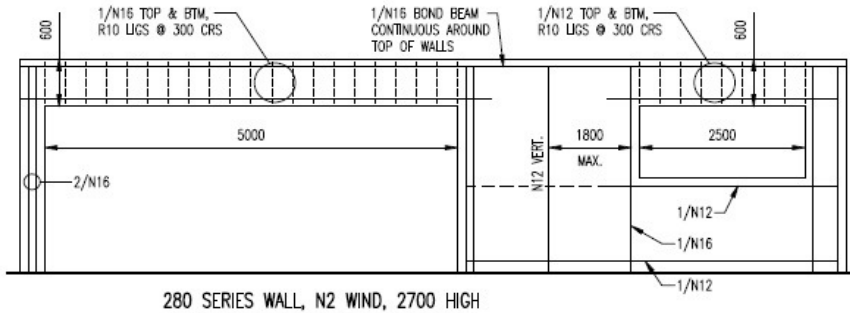

Fig 2h: 2700 High Wall, N2 Wind Rating, 280 Series ECO-Block (Max. roof load width: 10.0m)

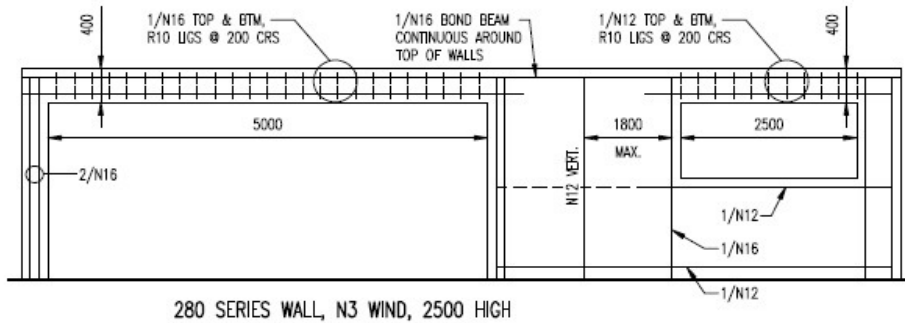

Fig 2i: 2500 High Wall, N3 Wind Rating, 280 Series ECO-Block (Max. roof load width: 6.8m)

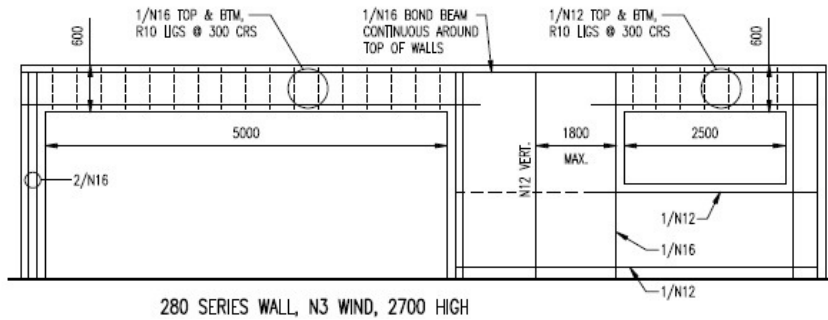

Fig 2j: 2700 High Wall, N3 Wind Rating, 280 Series ECO-Block (Max. roof load width: 10.0m)

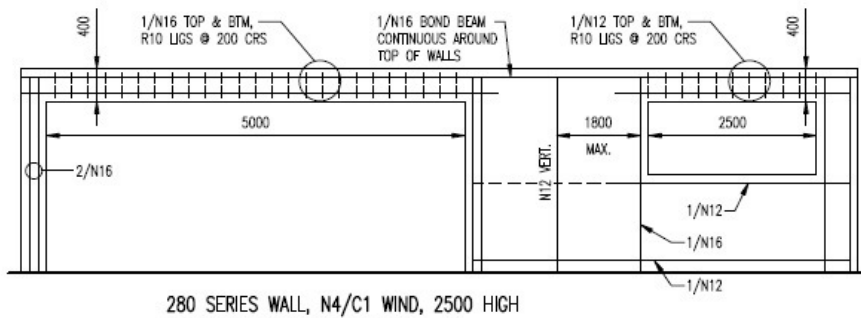

Fig 2k: 2500 High Wall, N4/C1 Wind Rating, 280 Series ECO-Block (Max. roof load width: 5.4m)

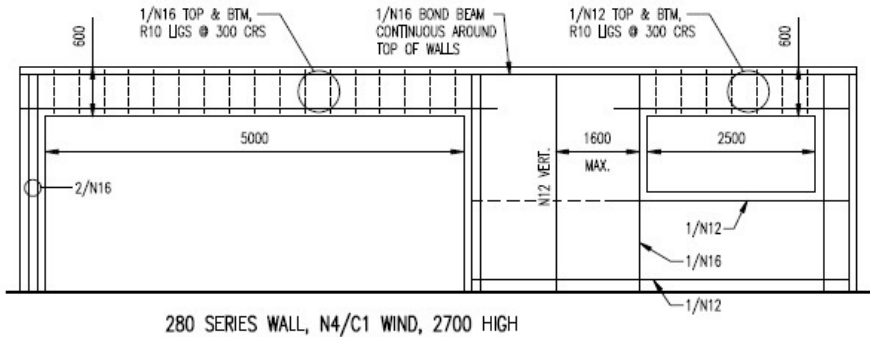

Fig 2l: 2700 High Wall, N4/C1 Wind Rating, 280 Series ECO-Block (Max. roof load width: 9.2m)

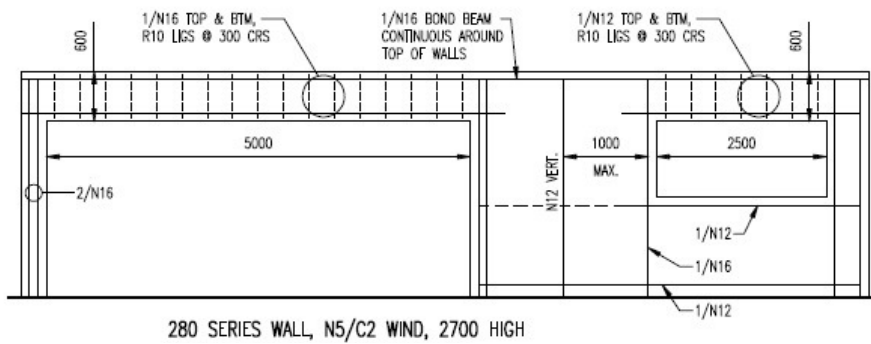

Fig 2m: 2700 High Wall, N5/C2 Wind Rating, 280 Series ECO-Block (Max. roof load width: 7.2m)

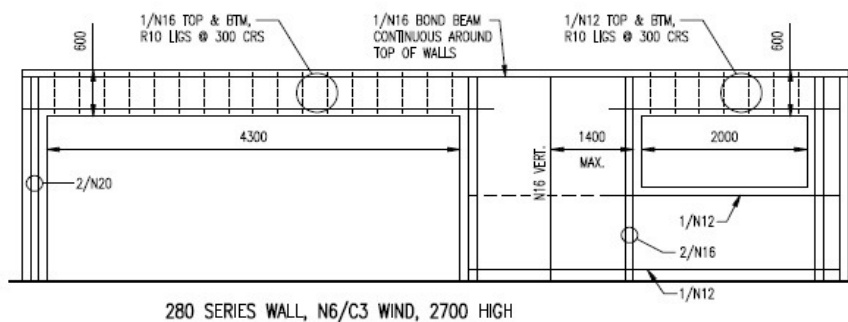

Fig 2n: 2700 High Wall, N6/C3 Wind Rating, 280 Series ECO-Block (Max. roof load width: 5.4m)

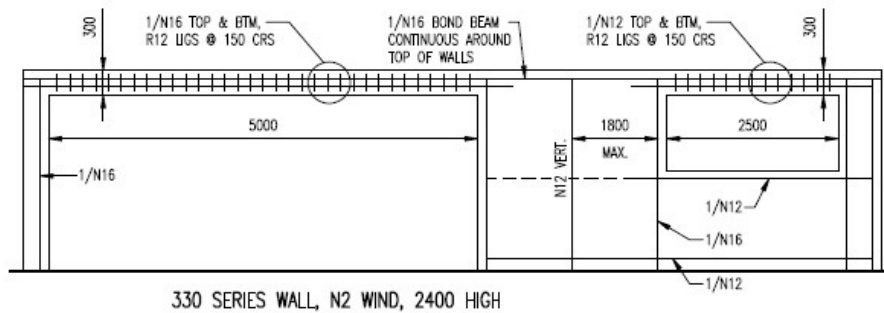

Fig 2o: 2400 High Wall, N2 Wind Rating, 330 Series ECO-Block (Max. roof load width: 5.8m)

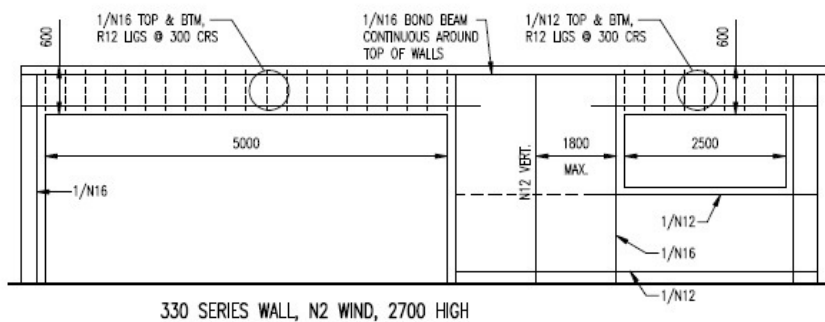

Fig 2p: 2700 High Wall, N2 Wind Rating, 330 Series ECO-Block (Max. roof load width: 10.0m)

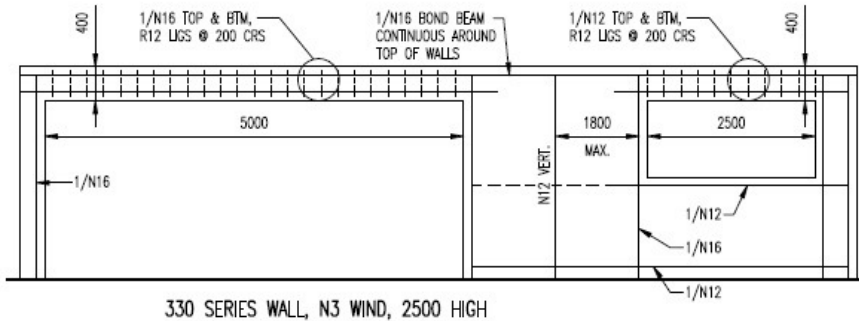

Fig 2q: 2500 High Wall, N3 Wind Rating, 330 Series ECO-Block (Max. roof load width: 9.6m)

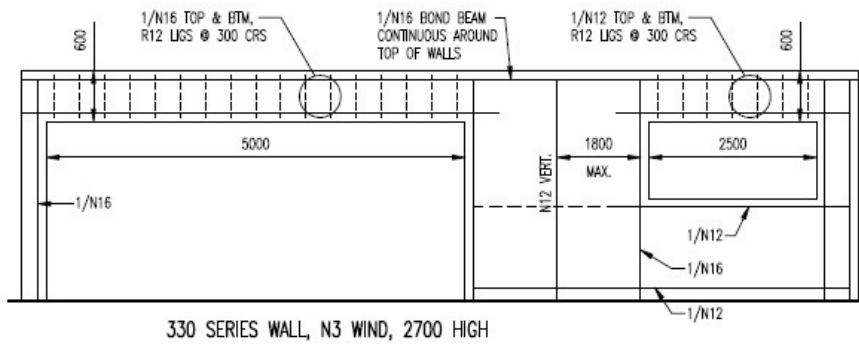

Fig 2r: 2700 High Wall, N3 Wind Rating, 330 Series ECO-Block (Max. roof load width: 10.0m)

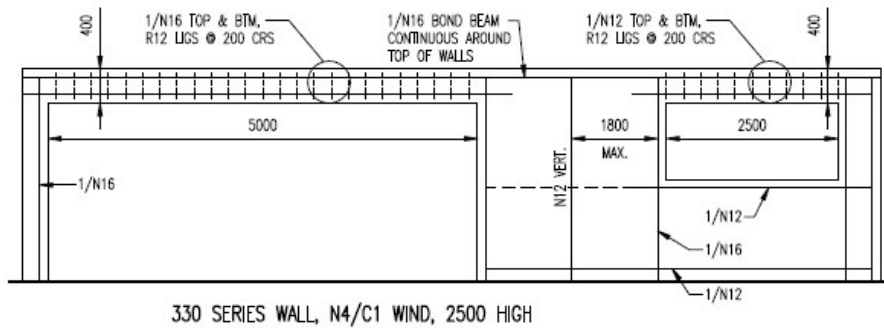

Fig 2s: 2500 High Wall, N4/C1 Wind Rating, 330 Series ECO-Block (Max. roof load width: 7.6m)

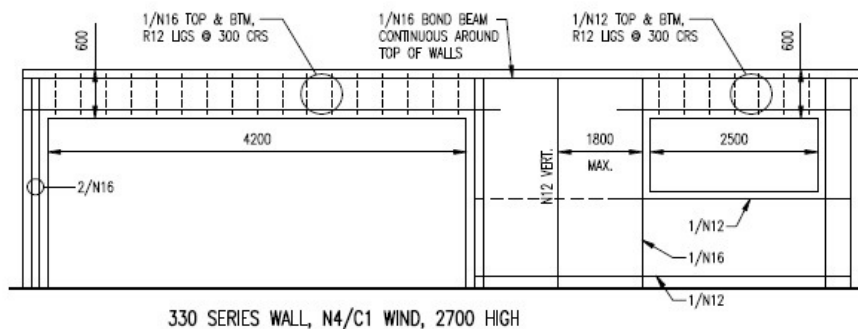

Fig 2t: 2700 High Wall, N4/C1 Wind Rating, 330 Series ECO-Block (Max. roof load width: 9.2m)

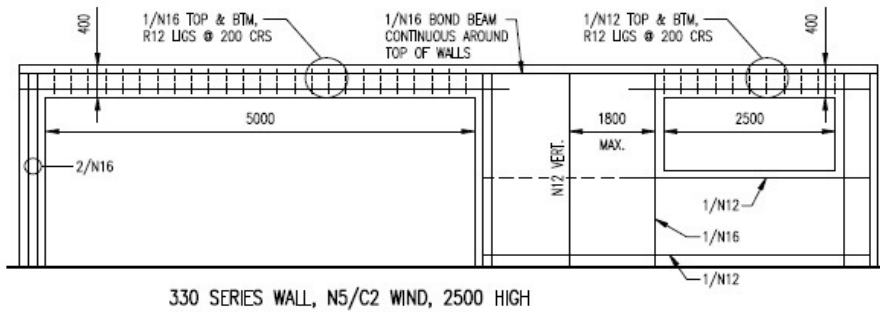

Fig 2u: 2500 High Wall, N5/C2 Wind Rating, 330 Series ECO-Block (Max. roof load width: 6.0m)

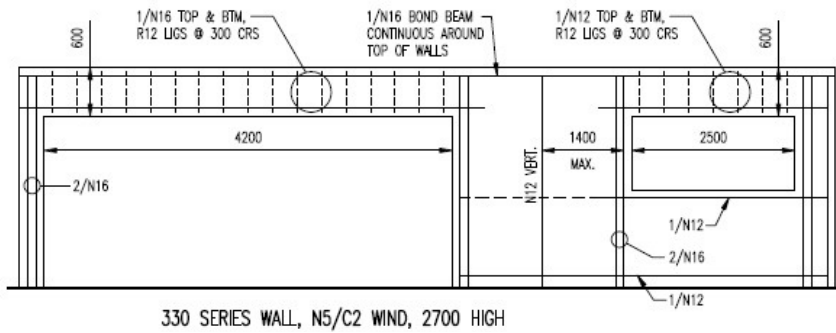

Fig 2v: 2700 High Wall, N5/C2 Wind Rating, 330 Series ECO-Block (Max. roof load width: 7.2m)

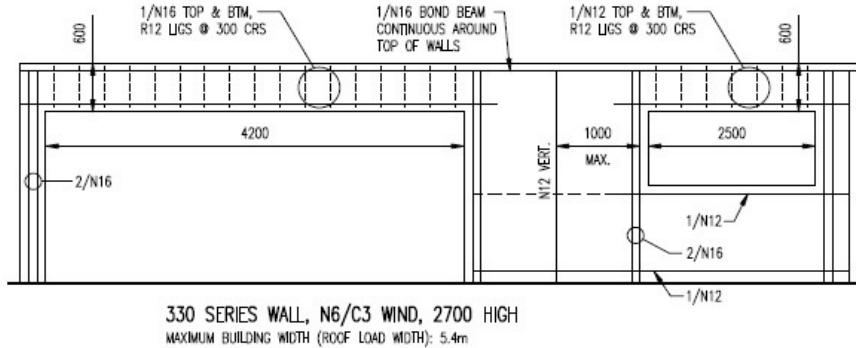

Fig 2w: 2700 High Wall, N6/C3 Wind Rating, 330 Series ECO-Block (Max. roof load width: 5.4m)



Simpler, Faster, Better

3.0 – Detailed Design of ECO-Block Frame

These tables provide information on reinforcement within the wall & also the conditions applicable to the wall elements.

When designing from these tables, it is important to remember the following:

- All steel reinforcement laps are to be as previously stated within the manual (cogged: N12-450, N16-600, N20-750; straight lapped: N12-600, N16-800, N20-1000)
- Starter bar size is to match wall steel size
- Roof load width indicates the width (or area) per metre length of lintel that is supported by the lintel beam

Table Summary

Table 3.1	Solid Wall Framing	Page 16
Table 3.2	Wall Framing Adjacent to Opening	Page 17
Table 3.3	Lintels – Uplift (metal sheet roof)	Pages 18-21
Table 3.3a	Lintels – Uplift (tiled roof)	Pages 22-25
Table 3.4	Lintels – Downwards Load Combination (metal sheet roof)	Pages 26-29
Table 3.4a	Lintels – Downwards Load Combination (tiled roof)	Pages 30-33
Table 3.5	Lintels – Supporting Floors	Pages 34-37



Simpler, Faster, Better

Solid Wall Framing

Table 3.1 Solid Wall Framing		Max. Reinforcement Spacing in Wall (mm)									
		Reinforcement N12					Reinforcement N16				
		Wall Height (mm)					Wall Height (mm)				
Wall type	Wind Rating	2400	2700	3000	3300	3600	2400	2700	3000	3300	3600
ECOBLOCK 230	N2	1800	1800	1800	1600	1400	1800	1800	1800	1800	1800
	N3	1800	1600	1200	1000	800	1800	1800	1800	1800	1400
	N4/C1	1200	1000	800	600	600	1800	1800	1400	1200	1000
	N5/C2	800	800	600	400	400	1400	1200	1000	800	600
	N6/C3	600	400	400	N/A	N/A	1000	800	600	600	400
	C4	400	N/A	N/A	N/A	N/A	800	600	400	400	N/A
ECOBLOCK 280	N2	1800	1800	1800	1800	1800	1800	1800	1800	1800	1800
	N3	1800	1800	1800	1600	1400	1800	1800	1800	1800	1800
	N4/C1	1800	1600	1400	1000	800	1800	1800	1800	1800	1600
	N5/C2	1400	1000	800	800	600	1800	1800	1600	1200	1000
	N6/C3	1000	800	600	N/A	N/A	1800	1400	1200	800	600
	C4	800	600	N/A	N/A	N/A	1400	1000	800	600	600
ECOBLOCK 330	N2	1800	1800	1800	1800	1800	1800	1800	1800	1800	1800
	N3	1800	1800	1800	1800	1800	1800	1800	1800	1800	1800
	N4/C1	1800	1800	1800	1400	1200	1800	1800	1800	1800	1800
	N5/C2	1800	1400	1200	1000	800	1800	1800	1800	1800	1600
	N6/C3	1400	1000	800	N/A	N/A	1800	1800	1600	1400	1000
	C4	1000	800	N/A	N/A	N/A	1800	1400	1200	1000	800



Simpler, Faster, Better

Wall Framing Adjacent to Opening

Table 3.2 Wall Framing Adj. to Opening		Maximum Opening Width (mm)														
		Reinforcement: 2/N12 or 1/N16					Reinforcement: 2/N16					Reinforcement: 2/N20				
		Wall Height (mm)					Wall Height (mm)					Wall Height (mm)				
Wall Type	Wind Rating	2400	2700	3000	3300	3600	2400	2700	3000	3300	3600	2400	2700	3000	3300	3600
ECOBLOCK 230	N2	5700	3800	2400	1700	1300	6000	6000	6000	5000	4000	6000	6000	6000	6000	5400
	N3	2400	1500	1400	1100	1000	6000	4600	3900	3200	2800	6000	6000	5100	4200	3600
	N4/C1	1600	1100	900	N/A	N/A	4200	3200	2600	1100	900	5500	4200	3400	1800	1500
	N5/C2	1100	N/A	N/A	N/A	N/A	2900	1100	800	700	800	3700	1800	1400	1200	1100
	N6/C3	800	N/A	N/A	N/A	N/A	2100	1000	900	500	600	2700	1500	1300	900	900
	C4	N/A	N/A	N/A	N/A	N/A	800	700	700	N/A	N/A	1300	1100	1000	700	N/A

ECOBLOCK 280	N2	6000	6000	6000	4500	3200	6000	6000	6000	6000	6000	6000	6000	6000	6000	6000
	N3	6000	4200	2700	2000	1600	6000	6000	6000	6000	5300	6000	6000	6000	6000	6000
	N4/C1	3000	2000	1400	1500	N/A	6000	6000	5100	4500	2300	6000	6000	6000	6000	4500
	N5/C2	1700	1500	1200	700	N/A	5600	4600	3700	2800	1700	6000	6000	6000	4600	3200
	N6/C3	1300	N/A	N/A	N/A	N/A	4200	2100	1500	1700	1500	6000	4100	3200	3000	2700
	C4	800	N/A	N/A	N/A	N/A	3000	1600	1300	1200	800	4900	3100	2500	2200	1700

ECOBLOCK 330	N2	6000	6000	6000	6000	5800	6000	6000	6000	6000	6000	6000	6000	6000	6000	6000
	N3	6000	6000	5100	3600	2400	6000	6000	6000	6000	6000	6000	6000	6000	6000	6000
	N4/C1	5500	3600	2200	2000	1600	6000	6000	6000	6000	5400	6000	6000	6000	6000	6000
	N5/C2	2600	2100	1500	1200	1100	6000	6000	5200	4300	3700	6000	6000	6000	6000	6000
	N6/C3	1800	1600	N/A	N/A	N/A	6000	5000	2400	1800	1900	6000	6000	5100	4100	3800
	C4	1400	1100	N/A	N/A	N/A	4500	3500	1800	1400	1300	6000	6000	3800	3100	2700



Simpler, Faster, Better

Lintels - Uplift

Table 3.3		Maximum roof load width - metal sheet roof (m)											
Lintels -Uplift		Reinforcement: N12											
Sheet Roof N12	Lintel Depth	300mm						400mm					
		Lintel Span (mm)						Lintel Span (mm)					
Wall Type	Wind Rating	2000	2800	3600	4400	5200	6000	2000	2800	3600	4400	5200	6000
ECOBLOCK 230	N2	10.0	10.0	8.4	5.4	3.6	2.5	10.0	10.0	10.0	7.9	5.4	3.8
	N3	10.0	8.0	4.7	3.0	2.0	1.4	10.0	10.0	6.9	4.4	3.0	2.1
	N4/C1	10.0	5.0	2.9	1.9	1.3	0.9	10.0	7.3	4.3	2.7	1.9	1.3
	N5/C2	6.5	3.2	1.9	1.2	0.8	0.6	9.5	4.8	2.8	1.8	1.2	0.9
	N6/C3	4.3	2.2	1.3	0.8	N/A	N/A	6.4	3.2	1.9	1.2	0.8	0.6
	C4	3.2	1.6	0.9	0.6	N/A	N/A	4.6	2.3	1.3	0.9	0.6	N/A

ECOBLOCK 280	N2	10.0	10.0	8.6	5.5	3.7	2.6	10.0	10.0	10.0	8.1	5.5	3.9
	N3	10.0	8.2	4.8	3.1	2.1	1.5	10.0	10.0	7.0	4.5	3.1	2.2
	N4/C1	10.0	5.1	3.0	1.9	1.3	0.9	10.0	7.4	4.4	2.8	1.9	1.3
	N5/C2	6.7	3.3	1.9	1.2	0.8	0.6	9.7	4.8	2.8	1.8	1.2	0.9
	N6/C3	4.5	2.2	1.3	0.8	0.6	N/A	6.5	3.2	1.9	1.2	0.8	0.6
	C4	3.2	1.6	0.9	0.6	N/A	N/A	4.7	2.3	1.4	0.9	0.6	N/A

ECOBLOCK 330	N2	10.0	10.0	8.8	5.6	3.8	2.7	10.0	10.0	10.0	10.0	7.6	5.4
	N3	10.0	8.3	4.9	3.1	2.1	1.5	10.0	10.0	9.4	6.1	4.2	3.0
	N4/C1	10.0	5.2	3.0	1.9	1.3	0.9	10.0	9.9	5.9	3.8	2.6	1.9
	N5/C2	6.8	3.4	2.0	1.3	0.9	0.6	10.0	6.5	3.8	2.5	1.7	1.2
	N6/C3	4.5	2.2	1.3	0.8	0.6	N/A	8.6	4.3	2.5	1.6	1.1	0.8
	C4	3.3	1.6	1.0	0.6	N/A	N/A	6.3	3.1	1.9	1.2	0.8	0.6

Table 3.3 Continued Lintels – Uplift		Maximum roof load width - metal sheet roof (m)											
		Reinforcement: N12											
Sheet Roof N12	Lintel Depth	500mm						600mm					
		Lintel Span (mm)						Lintel Span (mm)					
Wall Type	Wind Rating	2000	2800	3600	4400	5200	6000	2000	2800	3600	4400	5200	6000
ECOBLOCK 230	N2	10.0	10.0	10.0	10.0	7.2	5.0	10.0	10.0	10.0	10.0	8.9	6.3
	N3	10.0	10.0	9.1	5.8	4.0	2.8	10.0	10.0	10.0	7.3	5.0	3.5
	N4/C1	10.0	9.6	5.7	3.6	2.5	1.7	10.0	10.0	7.0	4.5	3.1	2.2
	N5/C2	10.0	6.3	3.7	2.4	1.6	1.1	10.0	7.8	4.6	2.9	2.0	1.4
	N6/C3	8.4	4.2	2.4	1.6	1.1	0.8	10.0	5.2	3.0	2.0	1.3	0.9
	C4	6.1	3.0	1.8	1.1	0.8	0.6	7.6	3.8	2.2	1.4	1.0	0.7

ECOBLOCK 280	N2	10.0	10.0	10.0	10.0	7.3	5.1	10.0	10.0	10.0	10.0	9.0	6.4
	N3	10.0	10.0	9.2	5.9	4.0	2.9	10.0	10.0	10.0	7.4	5.0	3.6
	N4/C1	10.0	9.8	5.7	3.7	2.5	1.8	10.0	10.0	7.1	4.6	3.1	2.2
	N5/C2	10.0	6.4	3.7	2.4	1.6	1.2	10.0	7.9	4.6	3.0	2.0	1.4
	N6/C3	8.5	4.2	2.5	1.6	1.1	0.8	10.0	5.2	3.1	2.0	1.4	1.0
	C4	6.2	3.1	1.8	1.2	0.8	0.6	7.7	3.8	2.2	1.4	1.0	0.7

ECOBLOCK 330	N2	10.0	10.0	10.0	10.0	7.3	5.2	10.0	10.0	10.0	10.0	10.0	8.0
	N3	10.0	10.0	9.3	6.0	4.1	2.9	10.0	10.0	10.0	8.3	5.9	4.5
	N4/C1	10.0	9.8	5.8	3.7	2.5	1.8	10.0	10.0	7.7	5.2	3.7	2.8
	N5/C2	10.0	6.4	3.8	2.4	1.6	1.2	10.0	8.3	5.0	3.4	2.4	1.8
	N6/C3	8.5	4.3	2.5	1.6	1.1	0.8	10.0	5.5	3.3	2.2	1.6	1.2
	C4	6.2	3.1	1.8	1.2	0.8	0.6	7.9	4.0	2.4	1.6	1.2	0.9



Simpler, Faster, Better

Table 3.3 Continued		Maximum roof load width - metal sheet roof (m)											
Lintels – Uplift		Reinforcement: N16											
Sheet Roof N16	Lintel Depth	300mm						400mm					
		Lintel Span (mm)						Lintel Span (mm)					
Wall Type	Wind Rating	2000	2800	3600	4400	5200	6000	2000	2800	3600	4400	5200	6000
ECOBLOCK 230	N2	10.0	10.0	10.0	9.4	6.5	4.7	10.0	10.0	10.0	10.0	9.8	7.1
	N3	10.0	10.0	8.0	5.2	3.6	2.6	10.0	10.0	10.0	7.9	5.5	4.0
	N4/C1	10.0	8.4	5.0	3.2	2.2	1.6	10.0	10.0	7.5	4.9	3.4	2.5
	N5/C2	10.0	5.5	3.2	2.1	1.5	1.1	10.0	8.2	4.9	3.2	2.2	1.6
	N6/C3	7.2	3.6	2.2	1.4	1.0	0.7	10.0	5.5	3.2	2.1	1.5	1.1
	C4	5.3	2.7	1.6	1.0	0.7	N/A	7.9	4.0	2.4	1.5	1.1	0.8

ECOBLOCK 280	N2	10.0	10.0	10.0	9.9	6.9	5.0	10.0	10.0	10.0	10.0	10.0	7.4
	N3	10.0	10.0	8.4	5.5	3.8	2.8	10.0	10.0	10.0	8.2	5.7	4.1
	N4/C1	10.0	8.8	5.2	3.4	2.4	1.7	10.0	10.0	7.8	5.1	3.5	2.6
	N5/C2	10.0	5.7	3.4	2.2	1.5	1.1	10.0	8.5	5.0	3.3	2.3	1.7
	N6/C3	7.6	3.8	2.3	1.5	1.0	0.7	10.0	5.7	3.4	2.2	1.5	1.1
	C4	5.5	2.8	1.7	1.1	0.7	N/A	8.2	4.1	2.4	1.6	1.1	0.8

ECOBLOCK 330	N2	10.0	10.0	10.0	10.0	7.0	5.1	10.0	10.0	10.0	10.0	10.0	10.0
	N3	10.0	10.0	8.6	5.6	3.9	2.8	10.0	10.0	10.0	10.0	7.8	5.7
	N4/C1	10.0	9.1	5.4	3.5	2.4	1.8	10.0	10.0	10.0	6.9	4.8	3.5
	N5/C2	10.0	5.9	3.5	2.3	1.6	1.1	10.0	10.0	6.8	4.5	3.1	2.3
	N6/C3	7.8	3.9	2.3	1.5	1.1	0.8	10.0	7.6	4.5	3.0	2.1	1.5
	C4	5.7	2.9	1.7	1.1	0.8	0.6	10.0	5.6	3.3	2.2	1.5	1.1



Simpler, Faster, Better

Table 3.3 Continued		Maximum roof load width - metal sheet roof (m)											
Lintels - Uplift		Reinforcement: N16											
Sheet Roof N16	Lintel Depth	500mm						600mm					
		Lintel Span (mm)						Lintel Span (mm)					
Wall Type	Wind Rating	2000	2800	3600	4400	5200	6000	2000	2800	3600	4400	5200	6000
ECOBLOCK 230	N2	10.0	10.0	10.0	10.0	10.0	9.6	10.0	10.0	10.0	10.0	10.0	10.0
	N3	10.0	10.0	10.0	10.0	7.3	5.3	10.0	10.0	10.0	10.0	9.2	6.7
	N4/C1	10.0	10.0	10.0	6.6	4.6	3.3	10.0	10.0	10.0	8.2	5.7	4.2
	N5/C2	10.0	10.0	6.5	4.3	3.0	2.2	10.0	10.0	8.2	5.3	3.7	2.7
	N6/C3	10.0	7.3	4.3	2.8	2.0	1.4	10.0	9.1	5.4	3.6	2.5	1.8
	C4	10.0	5.3	3.2	2.1	1.4	1.0	10.0	6.7	4.0	2.6	1.8	1.3

ECOBLOCK 280	N2	10.0	10.0	10.0	10.0	10.0	9.9	10.0	10.0	10.0	10.0	10.0	10.0
	N3	10.0	10.0	10.0	10.0	7.5	5.5	10.0	10.0	10.0	10.0	9.4	6.9
	N4/C1	10.0	10.0	10.0	6.7	4.7	3.4	10.0	10.0	12.8	8.4	5.8	4.3
	N5/C2	10.0	10.0	6.7	4.4	3.1	2.2	10.0	10.0	8.3	5.5	3.8	2.8
	N6/C3	10.0	7.5	4.5	2.9	2.0	1.5	10.0	9.3	5.5	3.6	2.5	1.8
	C4	10.0	5.5	3.2	2.1	1.5	1.1	10.0	6.8	4.0	2.6	1.8	1.3

ECOBLOCK 330	N2	10.0	10.0	10.0	10.0	10.0	10.0	10.0	10.0	10.0	10.0	10.0	10.0
	N3	10.0	10.0	10.0	10.0	7.6	5.6	10.0	10.0	10.0	10.0	10.0	7.8
	N4/C1	10.0	10.0	10.4	6.8	4.8	3.5	10.0	10.0	10.0	9.0	6.5	4.8
	N5/C2	10.0	10.0	6.8	4.4	3.1	2.2	10.0	10.0	8.8	5.9	4.2	3.2
	N6/C3	10.0	7.6	4.5	3.0	2.1	1.5	10.0	9.6	5.8	3.9	2.8	2.1
	C4	10.0	5.5	3.3	2.2	1.5	1.1	10.0	7.0	4.3	2.8	2.0	1.5



Simpler, Faster, Better

Table 3.3a		Maximum roof load width - tiled roof (m)											
Lintels – Uplift		Reinforcement: N12											
Tile Roof N12	Lintel Depth	300mm						400mm					
		Lintel Span (mm)						Lintel Span (mm)					
Wall Type	Wind Rating	2000	2800	3600	4400	5200	6000	2000	2800	3600	4400	5200	6000
ECOBLOCK 230	N2	10.0	10.0	10.0	10.0	7.9	5.5	10.0	10.0	10.0	10.0	10.0	8.2
	N3	10.0	10.0	6.7	4.3	2.9	2.0	10.0	10.0	9.8	6.3	4.3	3.0
	N4/C1	10.0	6.1	3.6	2.3	1.5	1.1	10.0	9.0	5.3	3.4	2.3	1.6
	N5/C2	7.4	3.7	2.1	1.4	0.9	0.6	10.0	5.4	3.2	2.0	1.4	1.0
	N6/C3	4.7	2.3	1.4	0.9	0.6	N/A	6.9	3.4	2.0	1.3	0.9	0.6
	C4	3.4	1.7	1.0	0.6	N/A	N/A	4.9	2.5	1.4	0.9	0.6	N/A
ECOBLOCK 280	N2	10.0	10.0	10.0	10.0	8.1	5.7	10.0	10.0	10.0	10.0	10.0	8.4
	N3	10.0	10.0	6.9	4.4	3.0	2.1	10.0	10.0	10.0	6.4	4.4	3.1
	N4/C1	10.0	6.3	3.7	2.3	1.6	1.1	10.0	9.2	5.4	3.4	2.3	1.6
	N5/C2	7.6	3.8	2.2	1.4	1.0	0.7	10.0	5.5	3.2	2.1	1.4	1.0
	N6/C3	4.8	2.4	1.4	0.9	0.6	N/A	7.0	3.5	2.1	1.3	0.9	0.6
	C4	3.4	1.7	1.0	0.6	N/A	N/A	5.0	2.5	1.5	0.9	0.6	N/A
ECOBLOCK 330	N2	10.0	10.0	10.0	10.0	8.2	5.8	10.0	10.0	10.0	10.0	10.0	10.0
	N3	10.0	10.0	7.0	4.5	3.0	2.1	10.0	10.0	10.0	8.8	6.0	4.3
	N4/C1	10.0	6.4	3.7	2.4	1.6	1.1	10.0	10.0	7.2	4.7	3.2	2.3
	N5/C2	7.7	3.8	2.2	1.4	1.0	0.7	10.0	7.4	4.3	2.8	1.9	1.4
	N6/C3	4.9	2.4	1.4	0.9	0.6	N/A	9.3	4.7	2.8	1.8	1.2	0.9
	C4	3.5	1.7	1.0	0.6	N/A	N/A	6.6	3.3	2.0	1.3	0.9	0.6



Simpler, Faster, Better

Table 3.3a Continued		Maximum roof load width - tiled roof (m)											
Lintels – Uplift		Reinforcement: N12											
Tile Roof N12	Lintel Depth	500mm						600mm					
		Lintel Span (mm)						Lintel Span (mm)					
Wall Type	Wind Rating	2000	2800	3600	4400	5200	6000	2000	2800	3600	4400	5200	6000
ECOBLOCK 230	N2	10.0	10.0	10.0	10.0	10.0	10.0	10.0	10.0	10.0	10.0	10.0	10.0
	N3	10.0	10.0	10.0	8.4	5.7	4.0	10.0	10.0	10.0	10.0	7.1	5.0
	N4/C1	10.0	10.0	7.0	4.5	3.0	2.1	10.0	10.0	8.6	5.6	3.8	2.7
	N5/C2	10.0	7.1	4.2	2.7	1.8	1.3	10.0	8.9	5.2	3.4	2.3	1.6
	N6/C3	9.1	4.5	2.7	1.7	1.2	0.8	10.0	5.6	3.3	2.1	1.5	1.0
	C4	6.5	3.2	1.9	1.2	0.8	0.6	8.0	4.0	2.4	1.5	1.0	0.7

ECOBLOCK 280	N2	10.0	10.0	10.0	10.0	10.0	10.0	10.0	10.0	10.0	10.0	10.0	10.0
	N3	10.0	10.0	10.0	8.5	5.8	4.1	10.0	10.0	10.0	10.0	7.2	5.1
	N4/C1	10.0	10.0	7.1	4.5	3.1	2.2	10.0	10.0	8.7	5.6	3.8	2.7
	N5/C2	10.0	7.2	4.2	2.7	1.9	1.3	10.0	9.0	5.3	3.4	2.3	1.6
	N6/C3	9.2	4.6	2.7	1.7	1.2	0.8	10.0	5.7	3.4	2.2	1.5	1.0
	C4	6.6	3.3	1.9	1.2	0.8	0.6	8.1	4.1	2.4	1.5	1.0	0.7

ECOBLOCK 330	N2	10.0	10.0	10.0	10.0	10.0	10.0	10.0	10.0	10.0	10.0	10.0	10.0
	N3	10.0	10.0	10.0	8.6	5.8	4.1	10.0	10.0	10.0	10.0	8.5	6.4
	N4/C1	10.0	10.0	7.1	4.6	3.1	2.2	10.0	10.0	9.5	6.3	4.5	3.4
	N5/C2	10.0	7.3	4.3	2.8	1.9	1.3	10.0	9.4	5.7	3.8	2.7	2.1
	N6/C3	9.3	4.6	2.7	1.8	1.2	0.8	10.0	6.0	3.6	2.4	1.7	1.3
	C4	6.6	3.3	1.9	1.2	0.8	0.6	8.4	4.3	2.6	1.7	1.2	0.9



Simpler, Faster, Better

Table 3.3a Continued		Maximum roof load width - tiled roof (m)											
Lintels - Uplift		Reinforcement: N16											
Tile Roof N16	Lintel Depth	300mm						400mm					
		Lintel Span (mm)						Lintel Span (mm)					
Wall Type	Wind Rating	2000	2800	3600	4400	5200	6000	2000	2800	3600	4400	5200	6000
ECOBLOCK 230	N2	10.0	10.0	10.0	10.0	10.0	10.0	10.0	10.0	10.0	10.0	10.0	10.0
	N3	10.0	10.0	10.0	7.5	5.2	3.7	10.0	10.0	10.0	10.0	7.8	5.7
	N4/C1	10.0	10.0	6.1	4.0	2.8	2.0	10.0	10.0	9.2	6.0	4.2	3.0
	N5/C2	10.0	6.2	3.7	2.4	1.7	1.2	10.0	9.3	5.5	3.6	2.5	1.8
	N6/C3	7.9	4.0	2.3	1.5	1.1	0.8	10.0	6.0	3.5	2.3	1.6	1.2
	C4	5.6	2.8	1.7	1.1	0.8	N/A	8.4	4.2	2.5	1.6	1.1	0.8

ECOBLOCK 280	N2	10.0	10.0	10.0	10.0	10.0	10.0	10.0	10.0	10.0	10.0	10.0	10.0
	N3	10.0	10.0	10.0	7.9	5.5	3.9	10.0	10.0	10.0	10.0	8.1	5.9
	N4/C1	10.0	10.0	6.4	4.2	2.9	2.1	10.0	10.0	9.5	6.2	4.3	3.1
	N5/C2	10.0	6.5	3.9	2.5	1.8	1.3	10.0	9.7	5.7	3.8	2.6	1.9
	N6/C3	8.3	4.2	2.5	1.6	1.1	0.8	10.0	6.2	3.7	2.4	1.7	1.2
	C4	5.9	3.0	1.8	1.1	0.8	0.6	8.7	4.4	2.6	1.7	1.2	0.9

ECOBLOCK 330	N2	10.0	10.0	10.0	10.0	10.0	10.0	10.0	10.0	10.0	10.0	10.0	10.0
	N3	10.0	10.0	10.0	8.1	5.6	4.1	10.0	10.0	10.0	10.0	10.0	8.2
	N4/C1	10.0	10.0	6.6	4.3	3.0	2.2	10.0	10.0	10.0	8.5	6.0	4.4
	N5/C2	10.0	6.7	4.0	2.6	1.8	1.3	10.0	10.0	7.8	5.1	3.6	2.6
	N6/C3	8.5	4.3	2.5	1.7	1.1	0.8	10.0	8.3	4.9	3.3	2.3	1.7
	C4	6.0	3.0	1.8	1.2	0.8	0.6	10.0	5.9	3.5	2.3	1.6	1.2



Simpler, Faster, Better

Table 3.3a Continued		Maximum roof load width - tiled roof (m)											
Lintels – Uplift		Reinforcement: N16											
Tile Roof N16	Lintel Depth	500mm						600mm					
		Lintel Span (mm)						Lintel Span (mm)					
Wall Type	Wind Rating	2000	2800	3600	4400	5200	6000	2000	2800	3600	4400	5200	6000
ECOBLOCK 230	N2	10.0	10.0	10.0	10.0	10.0	10.0	10.0	10.0	10.0	10.0	10.0	10.0
	N3	10.0	10.0	10.0	10.0	10.0	7.6	10.0	10.0	10.0	10.0	10.0	10.0
	N4/C1	10.0	10.0	10.0	8.1	5.6	4.1	10.0	10.0	10.0	10.0	7.0	5.1
	N5/C2	10.0	10.0	7.4	4.9	3.4	2.5	10.0	10.0	9.3	6.1	4.2	3.1
	N6/C3	10.0	7.9	4.7	3.1	2.2	1.6	10.0	9.9	5.9	3.9	2.7	2.0
	C4	10.0	5.7	3.4	2.2	1.5	1.1	10.0	7.1	4.2	2.8	1.9	1.4

ECOBLOCK 280	N2	10.0	10.0	10.0	10.0	10.0	10.0	10.0	10.0	10.0	10.0	10.0	10.0
	N3	10.0	10.0	10.0	10.0	10.0	7.8	10.0	10.0	10.0	10.0	10.0	9.8
	N4/C1	10.0	10.0	10.0	8.3	5.8	4.2	10.0	10.0	10.0	10.0	7.2	5.2
	N5/C2	10.0	10.0	7.6	5.0	3.5	2.5	10.0	10.0	9.5	6.2	4.3	3.2
	N6/C3	10.0	8.1	4.8	3.2	2.2	1.6	10.0	10.0	6.0	4.0	2.8	2.0
	C4	10.0	5.8	3.4	2.3	1.6	1.1	10.0	7.2	4.3	2.8	2.0	1.4

ECOBLOCK 330	N2	10.0	10.0	10.0	10.0	10.0	10.0	10.0	10.0	10.0	10.0	10.0	10.0
	N3	10.0	10.0	10.0	10.0	10.0	8.0	10.0	10.0	10.0	10.0	10.0	10.0
	N4/C1	10.0	10.0	10.0	8.4	5.8	4.3	10.0	10.0	10.0	10.0	7.9	6.0
	N5/C2	10.0	10.0	7.7	5.0	3.5	2.6	10.0	10.0	10.0	6.7	4.8	3.6
	N6/C3	10.0	8.2	4.9	3.2	2.2	1.6	10.0	10.0	6.3	4.2	3.0	2.3
	C4	10.0	5.9	3.5	2.3	1.6	1.2	10.0	7.5	4.5	3.0	2.2	1.6



Simpler, Faster, Better

Lintels -Downwards Load Combination

Table 3.4		Maximum roof load width – metal sheet roof (m)											
Lintels - Downloads		Reinforcement: N12											
Sheet Roof N12	Lintel Depth	300mm						400mm					
		Lintel Span (mm)						Lintel Span (mm)					
Wall Type	Wind Rating	2000	2800	3600	4400	5200	6000	2000	2800	3600	4400	5200	6000
ECOBLOCK 230	N2	10.0	8.6	4.9	3.0	2.0	1.3	10.0	10.0	7.2	4.5	3.0	2.0
	N3	10.0	6.5	3.7	2.3	1.5	1.0	10.0	9.6	5.5	3.4	2.3	1.5
	N4/C1	10.0	4.9	2.8	1.7	1.1	0.7	10.0	7.2	4.1	2.6	1.7	1.1
	N5/C2	7.3	3.6	2.1	1.3	0.8	N/A	10.0	5.3	3.0	1.9	1.2	0.8
	N6/C3	5.3	2.6	1.5	0.9	0.6	N/A	7.8	3.8	2.2	1.4	0.9	0.6
	C4	4.1	2.0	1.1	0.7	N/A	N/A	6.0	2.9	1.7	1.1	0.7	N/A
ECOBLOCK 280	N2	10.0	8.8	5.0	3.1	2.0	1.4	10.0	10.0	7.4	4.6	3.0	2.0
	N3	10.0	6.7	3.8	2.4	1.6	1.0	10.0	9.8	5.6	3.5	2.3	1.6
	N4/C1	10.0	5.0	2.9	1.8	1.2	0.8	10.0	7.3	4.2	2.6	1.7	1.2
	N5/C2	7.5	3.7	2.1	1.3	0.9	0.6	10.0	5.4	3.1	1.9	1.3	0.9
	N6/C3	5.4	2.7	1.5	1.0	0.6	N/A	7.9	3.9	2.2	1.4	0.9	0.6
	C4	4.2	2.0	1.2	0.7	N/A	N/A	6.1	3.0	1.7	1.1	0.7	N/A
ECOBLOCK 330	N2	10.0	8.9	5.1	3.2	2.1	1.4	10.0	10.0	10.0	6.4	4.3	3.0
	N3	10.0	6.8	3.9	2.4	1.6	1.1	10.0	10.0	7.7	4.9	3.3	2.3
	N4/C1	10.0	5.1	2.9	1.8	1.2	0.8	10.0	9.8	5.7	3.7	2.5	1.7
	N5/C2	7.6	3.7	2.1	1.3	0.9	0.6	10.0	7.2	4.2	2.7	1.8	1.3
	N6/C3	5.5	2.7	1.6	1.0	0.6	N/A	10.0	5.2	3.0	1.9	1.3	0.9
	C4	4.2	2.1	1.2	0.7	N/A	N/A	8.1	4.0	2.3	1.5	1.0	0.7



Simpler, Faster, Better

Table 3.4 Continued		Maximum roof load width – metal sheet roof (m)											
Lintels – Downloads		Reinforcement: N12											
Sheet Roof N12	Lintel Depth	500mm						600mm					
		Lintel Span (mm)						Lintel Span (mm)					
Wall Type	Wind Rating	2000	2800	3600	4400	5200	6000	2000	2800	3600	4400	5200	6000
ECOBLOCK 230	N2	10.0	10.0	9.6	6.0	4.0	2.7	10.0	10.0	10.0	7.5	5.0	3.4
	N3	10.0	10.0	7.3	4.6	3.0	2.0	10.0	10.0	9.1	5.7	3.8	2.6
	N4/C1	10.0	9.5	5.5	3.4	2.3	1.5	10.0	10.0	6.8	4.3	2.8	1.9
	N5/C2	10.0	7.0	4.0	2.5	1.7	1.1	10.0	8.7	5.0	3.2	2.1	1.4
	N6/C3	10.0	5.0	2.9	1.8	1.2	0.8	10.0	6.3	3.6	2.3	1.5	1.0
	C4	7.9	3.9	2.2	1.4	0.9	0.6	9.8	4.8	2.8	1.8	1.2	0.8

ECOBLOCK 280	N2	10.0	10.0	9.7	6.1	4.0	2.7	10.0	10.0	10.0	10.0	5.1	3.4
	N3	10.0	10.0	7.4	4.7	3.1	2.1	10.0	10.0	9.2	5.8	3.8	2.6
	N4/C1	10.0	9.6	5.6	3.5	2.3	1.6	10.0	10.0	6.9	4.4	2.9	2.0
	N5/C2	10.0	7.1	4.1	2.6	1.7	1.2	10.0	8.8	5.1	3.2	2.1	1.4
	N6/C3	10.0	5.1	3.0	1.9	1.2	0.8	10.0	6.4	3.7	2.3	1.5	1.0
	C4	8.0	3.9	2.3	1.4	0.9	0.6	9.9	4.9	2.8	1.8	1.2	0.8

ECOBLOCK 330	N2	10.0	10.0	9.8	6.2	4.1	2.8	10.0	10.0	10.0	7.7	5.1	3.5
	N3	10.0	10.0	7.5	4.7	3.1	2.1	10.0	10.0	9.3	5.8	3.9	2.6
	N4/C1	10.0	9.7	5.6	3.5	2.3	1.6	10.0	10.0	6.9	4.4	2.9	2.0
	N5/C2	10.0	7.1	4.1	2.6	1.7	1.2	10.0	8.8	5.1	3.2	2.1	1.5
	N6/C3	10.0	5.2	3.0	1.9	1.2	0.8	10.0	6.4	3.7	2.3	1.5	1.0
	C4	8.0	4.0	2.3	1.4	0.9	0.6	9.9	4.9	2.8	1.8	1.2	0.8



Simpler, Faster, Better

Table 3.4 Continued		Maximum roof load width – metal sheet roof (m)											
Lintels - Downloads		Reinforcement: N16											
Sheet Roof N16	Lintel Depth	300mm						400mm					
		Lintel Span (mm)						Lintel Span (mm)					
Wall Type	Wind Rating	2000	2800	3600	4400	5200	6000	2000	2800	3600	4400	5200	6000
ECOBLOCK 230	N2	10.0	10.0	8.6	5.5	3.7	2.6	10.0	10.0	10.0	8.3	5.7	4.0
	N3	10.0	10.0	6.5	4.2	2.8	2.0	10.0	10.0	9.8	6.3	4.3	3.1
	N4/C1	10.0	8.3	4.9	3.1	2.1	1.5	10.0	10.0	7.4	4.8	3.3	2.3
	N5/C2	10.0	6.1	3.6	2.3	1.6	1.1	10.0	9.2	5.4	3.5	2.4	1.7
	N6/C3	8.9	4.4	2.6	1.7	1.1	0.8	10.0	6.7	3.9	2.5	1.7	1.2
	C4	6.8	3.4	2.0	1.3	0.9	0.6	10.0	5.1	3.0	1.9	1.3	0.9

ECOBLOCK 280	N2	10.0	10.0	9.0	5.8	4.0	2.8	10.0	10.0	10.0	8.6	5.9	4.2
	N3	10.0	10.0	6.9	4.4	3.0	2.1	10.0	10.0	10.0	6.6	4.5	3.2
	N4/C1	10.0	8.8	5.2	3.3	2.3	1.6	10.0	10.0	7.6	4.9	3.4	2.4
	N5/C2	10.0	6.5	3.8	2.4	1.7	1.2	10.0	9.6	5.6	3.6	2.5	1.8
	N6/C3	9.4	4.7	2.7	1.8	1.2	0.8	10.0	6.9	4.1	2.6	1.8	1.3
	C4	7.2	3.6	2.1	1.4	0.9	0.7	10.0	5.3	3.1	2.0	1.4	1.0

ECOBLOCK 330	N2	10.0	10.0	9.3	6.0	4.1	2.9	10.0	10.0	10.0	10.0	8.2	6.0
	N3	10.0	10.0	7.0	4.5	3.1	2.2	10.0	10.0	10.0	9.1	6.3	4.5
	N4/C1	10.0	9.0	5.3	3.4	2.3	1.6	10.0	10.0	10.0	6.8	4.7	3.4
	N5/C2	10.0	6.6	3.9	2.5	1.7	1.2	10.0	10.0	7.7	5.0	3.5	2.5
	N6/C3	9.6	4.8	2.8	1.8	1.2	0.9	10.0	9.3	5.5	3.6	2.5	1.8
	C4	7.4	3.7	2.2	1.4	0.9	0.7	10.0	7.2	4.2	2.8	1.9	1.4



Simpler, Faster, Better

Table 3.4 Continued Lintels – Downloads		Maximum roof load width – metal sheet roof (m)											
		Reinforcement: N16											
Sheet Roof N16	Lintel Depth	500mm						600mm					
		Lintel Span (mm)						Lintel Span (mm)					
Wall Type	Wind Rating	2000	2800	3600	4400	5200	6000	2000	2800	3600	4400	5200	6000
ECOBLOCK 230	N2	10.0	10.0	10.0	10.0	7.7	5.5	10.0	10.0	10.0	10.0	9.6	6.9
	N3	10.0	10.0	10.0	8.5	5.8	4.2	10.0	10.0	10.0	10.0	7.3	5.2
	N4/C1	10.0	10.0	9.9	6.4	4.4	3.1	10.0	10.0	10.0	8.0	5.5	3.9
	N5/C2	10.0	10.0	7.3	4.7	3.2	2.3	10.0	10.0	9.1	5.9	4.1	2.9
	N6/C3	10.0	8.9	5.2	3.4	2.3	1.7	10.0	10.0	6.6	4.3	2.9	2.1
	C4	10.0	6.8	4.0	2.6	1.8	1.3	10.0	8.6	5.0	3.3	2.2	1.6

ECOBLOCK 280	N2	10.0	10.0	10.0	10.0	7.9	5.6	10.0	10.0	10.0	10.0	9.9	7.1
	N3	10.0	10.0	10.0	8.8	6.0	4.3	10.0	10.0	10.0	10.0	7.5	5.4
	N4/C1	10.0	10.0	10.0	6.6	4.5	3.2	10.0	10.0	10.0	8.2	5.6	4.0
	N5/C2	10.0	10.0	7.5	4.8	3.3	2.4	10.0	10.0	9.3	6.0	4.1	3.0
	N6/C3	10.0	9.1	5.4	3.5	2.4	1.7	10.0	10.0	6.7	4.4	3.0	2.1
	C4	10.0	7.0	4.1	2.7	1.8	1.3	10.0	8.7	5.2	3.3	2.3	1.6

ECOBLOCK 330	N2	10.0	10.0	10.0	10.0	8.0	5.7	10.0	10.0	10.0	10.0	10.0	7.1
	N3	10.0	10.0	10.0	8.9	6.1	4.3	10.0	10.0	10.0	10.0	7.6	5.4
	N4/C1	10.0	10.0	10.0	6.7	4.6	3.3	10.0	10.0	10.0	8.3	5.7	4.1
	N5/C2	10.0	10.0	7.6	4.9	3.4	2.4	10.0	10.0	9.4	6.1	4.2	3.0
	N6/C3	10.0	9.3	5.5	3.5	2.4	1.7	10.0	10.0	6.8	4.4	3.0	2.2
	C4	10.0	7.1	4.2	2.7	1.9	1.3	10.0	8.8	5.2	3.4	2.3	1.7



Simpler, Faster, Better

Table 3.4a Lintels - Downloads		Maximum roof load width – tiled roof (m)											
		Reinforcement: N12											
Tile Roof N12	Lintel Depth	300mm						400mm					
		Lintel Span (mm)						Lintel Span (mm)					
Wall Type	Wind Rating	2000	2800	3600	4400	5200	6000	2000	2800	3600	4400	5200	6000
ECOBLOCK 230	N2	10.0	6.1	3.5	2.2	1.4	0.9	10.0	8.9	5.1	3.2	2.1	1.4
	N3	10.0	5.0	2.8	1.8	1.1	0.8	10.0	7.3	4.2	2.6	1.7	1.2
	N4/C1	8.1	4.0	2.3	1.4	0.9	0.6	10.0	5.8	3.3	2.1	1.4	0.9
	N5/C2	6.3	3.1	1.8	1.1	0.7	N/A	9.2	4.5	2.6	1.6	1.1	0.7
	N6/C3	4.7	2.3	1.3	0.8	N/A	N/A	6.9	3.4	2.0	1.2	0.8	N/A
	C4	4.1	2.0	1.1	0.7	N/A	N/A	5.4	2.7	1.5	1.0	0.6	N/A

ECOBLOCK 280	N2	10.0	6.2	3.6	2.2	1.4	1.0	10.0	9.1	5.2	3.3	2.2	1.4
	N3	10.0	5.1	2.9	1.8	1.2	0.8	10.0	7.4	4.3	2.7	1.8	1.2
	N4/C1	8.3	4.1	2.3	1.4	0.9	0.6	10.0	5.9	3.4	2.1	1.4	0.9
	N5/C2	6.4	3.2	1.8	1.1	0.7	N/A	9.3	4.6	2.6	1.7	1.1	0.7
	N6/C3	4.8	2.4	1.4	0.8	0.6	N/A	7.0	3.5	2.0	1.2	0.8	0.6
	C4	3.8	1.9	1.1	0.7	N/A	N/A	5.5	2.7	1.6	1.0	0.6	N/A

ECOBLOCK 330	N2	10.0	6.3	3.6	2.3	1.5	1.0	10.0	10.0	7.1	4.5	3.1	2.1
	N3	10.0	5.2	3.0	1.8	1.2	0.8	10.0	10.0	5.8	3.7	2.5	1.7
	N4/C1	8.4	4.1	2.4	1.5	1.0	0.6	10.0	8.0	4.6	3.0	2.0	1.4
	N5/C2	6.5	3.2	1.8	1.1	0.7	N/A	10.0	6.2	3.6	2.3	1.5	1.1
	N6/C3	4.9	2.4	1.4	0.9	0.6	N/A	9.4	4.6	2.7	1.7	1.2	0.8
	C4	3.9	1.9	1.1	0.7	N/A	N/A	7.4	3.7	2.1	1.4	0.9	0.6



Simpler, Faster, Better

Table 3.4a Continued		Maximum roof load width – tiled roof (m)											
Lintels – Downloads		Reinforcement: N12											
Tile Roof N12	Lintel Depth	500mm						600mm					
		Lintel Span (mm)						Lintel Span (mm)					
Wall Type	Wind Rating	2000	2800	3600	4400	5200	6000	2000	2800	3600	4400	5200	6000
ECOBLOCK 230	N2	10.0	10.0	6.8	4.3	2.8	1.9	10.0	10.0	8.5	5.3	3.5	2.4
	N3	10.0	9.6	5.6	3.5	2.3	1.6	10.0	10.0	6.9	4.4	2.9	2.0
	N4/C1	10.0	7.7	4.4	2.8	1.8	1.2	10.0	9.6	5.5	3.5	2.3	1.6
	N5/C2	10.0	6.0	3.4	2.2	1.4	1.0	10.0	7.4	4.3	2.7	1.8	1.2
	N6/C3	9.1	4.5	2.6	1.6	1.1	0.7	10.0	5.6	3.2	2.0	1.3	0.9
	C4	7.2	3.5	2.0	1.3	0.8	0.6	8.9	4.4	2.5	1.6	1.1	0.7

ECOBLOCK 280	N2	10.0	10.0	6.9	4.3	2.9	1.9	10.0	10.0	8.6	5.4	3.6	2.4
	N3	10.0	9.8	5.6	3.5	2.3	1.6	10.0	10.0	7.0	4.4	2.9	2.0
	N4/C1	10.0	7.8	4.5	2.8	1.9	1.3	10.0	9.7	5.6	3.5	2.3	1.6
	N5/C2	10.0	6.0	3.5	2.2	1.4	1.0	10.0	7.5	4.3	2.7	1.8	1.2
	N6/C3	9.2	4.6	2.6	1.7	1.1	0.7	10.0	5.6	3.3	2.1	1.4	0.9
	C4	7.3	3.6	2.1	1.3	0.9	0.6	9.0	4.4	2.6	1.6	1.1	0.7

ECOBLOCK 330	N2	10.0	10.0	6.9	4.4	2.9	2.0	10.0	10.0	8.6	5.4	3.6	2.4
	N3	10.0	9.8	5.7	3.6	2.4	1.6	10.0	10.0	7.0	4.4	2.9	2.0
	N4/C1	10.0	7.9	4.5	2.9	1.9	1.3	10.0	9.7	5.6	3.5	2.3	1.6
	N5/C2	10.0	6.1	3.5	2.2	1.5	1.0	10.0	7.5	4.4	2.7	1.8	1.2
	N6/C3	9.3	4.6	2.6	1.7	1.1	0.7	10.0	5.7	3.3	2.1	1.4	0.9
	C4	7.3	3.6	2.1	1.3	0.9	0.6	9.1	4.5	2.6	1.6	1.1	0.7



Simpler, Faster, Better

Table 3.4a		Maximum roof load width – tiled roof (m)											
Lintels - Downloads		Reinforcement: N16											
Tile Roof N16	Lintel Depth	300mm						400mm					
		Lintel Span (mm)						Lintel Span (mm)					
Wall Type	Wind Rating	2000	2800	3600	4400	5200	6000	2000	2800	3600	4400	5200	6000
ECOBLOCK 230	N2	10.0	10.0	6.1	3.9	2.6	1.9	10.0	10.0	9.2	5.9	4.0	2.9
	N3	10.0	8.5	5.0	3.2	2.2	1.5	10.0	10.0	7.5	4.8	3.3	2.3
	N4/C1	10.0	6.8	4.0	2.5	1.7	1.2	10.0	10.0	6.0	3.9	2.6	1.9
	N5/C2	10.0	5.2	3.1	2.0	1.3	0.9	10.0	7.9	4.6	3.0	2.0	1.4
	N6/C3	7.9	3.9	2.3	1.5	1.0	0.7	10.0	5.9	3.5	2.2	1.5	1.1
	C4	6.2	3.1	1.8	1.2	0.8	0.6	9.4	4.7	2.7	1.8	1.2	0.9

ECOBLOCK 280	N2	10.0	10.0	6.4	4.1	2.8	2.0	10.0	10.0	9.5	6.1	4.2	3.0
	N3	10.0	8.9	5.2	3.4	2.3	1.6	10.0	10.0	7.8	5.0	3.4	2.4
	N4/C1	10.0	7.1	4.2	2.7	1.8	1.3	10.0	10.0	6.2	4.0	2.7	1.9
	N5/C2	10.0	5.5	3.2	2.1	1.4	1.0	10.0	8.2	4.8	3.1	2.1	1.5
	N6/C3	8.3	4.1	2.4	1.6	1.1	0.8	10.0	6.1	3.6	2.3	1.6	1.1
	C4	6.6	3.3	1.9	1.2	0.8	0.6	9.7	4.8	2.8	1.8	1.3	0.9

ECOBLOCK 330	N2	10.0	10.0	6.6	4.2	2.9	2.0	10.0	10.0	10.0	8.4	5.8	4.2
	N3	10.0	9.1	5.4	3.5	2.4	1.7	10.0	10.0	10.0	6.9	4.8	3.4
	N4/C1	10.0	7.3	4.3	2.8	1.9	1.3	10.0	10.0	8.4	5.5	3.8	2.7
	N5/C2	10.0	5.6	3.3	2.1	1.5	1.0	10.0	10.0	6.5	4.3	3.0	2.1
	N6/C3	8.5	4.3	2.5	1.6	1.1	0.8	10.0	8.3	4.9	3.2	2.2	1.6
	C4	6.7	3.3	2.0	1.3	0.9	0.6	10.0	6.5	3.9	2.5	1.7	1.3



Simpler, Faster, Better

Table 3.4a Continued		Maximum roof load width – tiled roof (m)											
Lintels - Downloads		Reinforcement: N16											
Tile Roof N16	Lintel Depth	500mm						600mm					
		Lintel Span (mm)						Lintel Span (mm)					
Wall Type	Wind Rating	2000	2800	3600	4400	5200	6000	2000	2800	3600	4400	5200	6000
ECOBLOCK 230	N2	10.0	10.0	10.0	7.9	5.4	3.9	10.0	10.0	10.0	9.9	6.8	4.9
	N3	10.0	10.0	10.0	6.5	4.4	3.2	10.0	10.0	10.0	8.1	5.6	4.0
	N4/C1	10.0	10.0	8.0	5.2	3.5	2.5	10.0	10.0	10.0	6.5	4.5	3.2
	N5/C2	10.0	10.5	6.2	4.0	2.7	2.0	10.0	10.0	7.8	5.0	3.5	2.5
	N6/C3	10.0	7.9	4.7	3.0	2.1	1.5	10.0	9.9	5.8	3.8	2.6	1.9
	C4	10.0	6.2	3.7	2.4	1.6	1.2	10.0	7.8	4.6	3.0	2.0	1.5

ECOBLOCK 280	N2	10.0	10.0	10.0	8.1	5.6	4.0	10.0	10.0	10.0	10.0	7.0	5.0
	N3	10.0	10.0	10.0	6.7	4.6	3.3	10.0	10.0	10.0	8.3	5.7	4.1
	N4/C1	10.0	10.0	8.2	5.3	3.6	2.6	10.0	10.0	10.0	6.6	4.6	3.3
	N5/C2	10.0	10.0	6.4	4.1	2.8	2.0	10.0	10.0	7.9	5.1	3.5	2.5
	N6/C3	10.0	8.1	4.8	3.1	2.1	1.5	10.0	10.0	6.0	3.9	2.7	1.9
	C4	10.0	6.4	3.8	2.4	1.7	1.2	10.0	8.0	4.7	3.0	2.1	1.5

ECOBLOCK 330	N2	10.0	10.0	10.0	8.2	5.7	4.0	10.0	10.0	10.0	10.0	7.1	5.0
	N3	10.0	10.0	10.0	6.7	4.6	3.3	10.0	10.0	10.0	8.4	5.8	4.1
	N4/C1	10.0	10.0	8.3	5.4	3.7	2.6	10.0	10.0	10.0	6.7	4.6	3.3
	N5/C2	10.0	10.0	6.4	4.2	2.9	2.0	10.0	10.0	8.0	5.2	3.6	2.6
	N6/C3	10.0	8.2	4.9	3.1	2.2	1.5	10.0	10.0	6.0	3.9	2.7	1.9
	C4	10.0	6.5	3.8	2.5	1.7	1.2	10.0	8.1	4.8	3.1	2.1	1.5



Simpler, Faster, Better

Lintels - Supporting Floors

Table 3.5 Lintels- Floors N12			Maximum floor load width (m)											
			Reinforcement: N12											
Lintel Depth		300mm						400mm						
LOADS (kPa)		Lintel Span (mm)						Lintel Span (mm)						
Wall Type	DL	LL	1500	1800	2100	2400	2700	3000	1500	1800	2100	2400	2700	3000
ECOBLOCK 230	1.0	1.5	6.0	4.2	3.0	2.2	1.7	1.3	6.0	6.0	4.4	3.3	2.5	2.0
		2.0	5.0	3.4	2.5	1.8	1.4	1.1	6.0	5.0	3.6	2.7	2.1	1.6
		3.0	3.7	2.5	1.8	1.4	1.0	0.8	5.4	3.7	2.7	2.0	1.5	1.2
	4.8	1.5	2.6	1.8	1.3	1.0	0.7	0.6	3.9	2.6	1.9	1.4	1.1	0.9
		2.0	2.4	1.6	1.2	0.9	0.7	N/A	3.5	2.4	1.7	1.3	1.0	0.8
		3.0	2.1	1.4	1.0	0.8	0.6	N/A	3.0	2.1	1.5	1.1	0.9	0.7
ECOBLOCK 280	1.0	1.5	6.0	4.3	3.1	2.3	1.8	1.4	6.0	6.0	4.5	3.4	2.6	2.0
		2.0	5.2	3.5	2.5	1.9	1.5	1.1	6.0	5.1	3.7	2.8	2.1	1.7
		3.0	3.8	2.6	1.9	1.4	1.1	0.8	5.5	3.8	2.7	2.0	1.6	1.2
	4.8	1.5	2.7	1.8	1.3	1.0	0.8	0.6	3.9	2.7	1.9	1.5	1.1	0.9
		2.0	2.5	1.7	1.2	0.9	0.7	N/A	3.6	2.5	1.8	1.3	1.0	0.8
		3.0	2.1	1.4	1.0	0.8	0.6	N/A	3.1	2.1	1.5	1.1	0.9	0.7
ECOBLOCK 330	1.0	1.5	6.0	4.3	3.1	2.3	1.8	1.4	6.0	6.0	4.5	3.4	2.6	2.1
		2.0	5.2	3.6	2.6	1.9	1.5	1.2	6.0	5.2	3.7	2.8	2.1	1.7
		3.0	3.9	2.6	1.9	1.4	1.1	0.9	5.6	3.8	2.8	2.1	1.6	1.2
	4.8	1.5	2.7	1.9	1.3	1.0	0.8	0.6	4.0	2.7	2.0	1.5	1.1	0.9
		2.0	2.5	1.7	1.2	0.9	0.7	0.6	3.6	2.5	1.8	1.3	1.0	0.8
		3.0	2.1	1.5	1.1	0.8	0.6	N/A	3.1	2.1	1.5	1.1	0.9	0.7



Simpler, Faster, Better

Table 3.5 Continued Lintels - Floors N12			Maximum floor load width (m) Reinforcement: N12											
Wall Type	Lintel Depth		500mm						600mm					
	LOADS (kPa)		Lintel Span (mm)						Lintel Span (mm)					
	DL	LL	1500	1800	2100	2400	2700	3000	1500	1800	2100	2400	2700	3000
ECOBLOCK 230	1.0	1.5	6.0	6.0	5.8	4.4	3.4	2.6	6.0	6.0	6.0	5.6	4.4	3.5
		2.0	6.0	6.0	4.8	3.6	2.8	2.2	6.0	6.0	6.0	4.6	3.6	2.8
		3.0	6.0	4.9	3.5	2.6	2.0	1.6	6.0	6.0	4.5	3.4	2.6	2.1
	4.8	1.5	5.1	3.5	2.5	1.9	1.4	1.1	6.0	4.4	3.2	2.4	1.9	1.5
		2.0	4.7	3.2	2.3	1.7	1.3	1.0	5.9	4.0	2.9	2.2	1.7	1.4
		3.0	4.0	2.7	2.0	1.5	1.1	0.9	5.0	3.4	2.5	1.9	1.5	1.2

ECOBLOCK 280	1.0	1.5	6.0	6.0	5.8	4.4	3.4	2.6	6.0	6.0	6.0	5.7	4.4	3.5
		2.0	6.0	6.0	4.8	3.6	2.8	2.2	6.0	6.0	6.0	4.7	3.6	2.9
		3.0	6.0	4.9	3.5	2.6	2.0	1.6	6.0	6.0	4.5	3.4	2.7	2.1
	4.8	1.5	5.1	3.5	2.5	1.9	1.4	1.1	6.0	4.5	3.2	2.4	1.9	1.5
		2.0	4.7	3.2	2.3	1.7	1.3	1.0	5.9	4.1	3.0	2.2	1.7	1.4
		3.0	4.0	2.7	2.0	1.5	1.1	0.9	5.1	3.5	2.5	1.9	1.5	1.2

ECOBLOCK 330	1.0	1.5	6.0	6.0	5.9	4.4	3.4	2.7	6.0	6.0	6.0	5.7	4.4	3.5
		2.0	6.0	6.0	4.9	3.6	2.8	2.2	6.0	6.0	6.0	4.7	3.6	2.9
		3.0	6.0	5.0	3.6	2.7	2.1	1.6	6.0	6.0	4.6	3.5	2.7	2.1
	4.8	1.5	5.2	3.5	2.6	1.9	1.5	1.2	6.0	4.5	3.3	2.5	1.9	1.5
		2.0	4.7	3.2	2.3	1.7	1.3	1.1	6.0	4.1	3.0	2.2	1.7	1.4
		3.0	4.0	2.8	2.0	1.5	1.1	0.9	5.1	3.5	2.5	1.9	1.5	1.2



Simpler, Faster, Better

Table 3.5 Continued Lintels – Floors N16			Maximum floor load width (m) Reinforcement: N16											
			300mm						400mm					
Lintel Depth			Lintel Span (mm)						Lintel Span (mm)					
LOADS (kPa)														
Wall Type	DL	LL	1500	1800	2100	2400	2700	3000	1500	1800	2100	2400	2700	3000
ECOBLOCK 230	1.0	1.5	6.0	6.0	5.1	3.9	3.0	2.4	6.0	6.0	6.0	5.8	4.5	3.6
		2.0	6.0	5.8	4.2	3.2	2.5	2.0	6.0	6.0	6.0	4.8	3.7	3.0
		3.0	6.0	4.3	3.1	2.3	1.8	1.4	6.0	6.0	4.7	3.5	2.7	2.2
	4.8	1.5	4.4	3.0	2.2	1.7	1.3	1.0	6.0	4.6	3.3	2.5	2.0	1.6
		2.0	4.1	2.8	2.0	1.5	1.2	0.9	6.0	4.2	3.0	2.3	1.8	1.4
		3.0	3.5	2.4	1.7	1.3	1.0	0.8	5.2	3.6	2.6	2.0	1.5	1.2

ECOBLOCK 280	1.0	1.5	6.0	6.0	5.4	4.1	3.2	2.5	6.0	6.0	6.0	6.0	4.7	3.7
		2.0	6.0	6.0	4.4	3.3	2.6	2.1	6.0	6.0	6.0	5.0	3.9	3.1
		3.0	6.0	4.5	3.3	2.5	1.9	1.5	6.0	6.0	4.8	3.7	2.8	2.3
	4.8	1.5	4.7	3.2	2.3	1.8	1.4	1.1	6.0	4.7	3.4	2.6	2.0	1.6
		2.0	4.3	2.9	2.1	1.6	1.2	1.0	6.0	4.3	3.1	2.4	1.9	1.5
		3.0	3.6	2.5	1.8	1.4	1.1	0.8	5.4	3.7	2.7	2.0	1.6	1.3

ECOBLOCK 330	1.0	1.5	6.0	6.0	5.5	4.2	3.2	2.6	6.0	6.0	6.0	6.0	4.8	3.8
		2.0	6.0	6.0	4.5	3.4	2.7	2.1	6.0	6.0	6.0	5.0	3.9	3.1
		3.0	6.0	4.6	3.3	2.5	2.0	1.6	6.0	6.0	4.9	3.7	2.9	2.3
	4.8	1.5	4.8	3.3	2.4	1.8	1.4	1.1	6.0	4.8	3.5	2.6	2.1	1.6
		2.0	4.4	3.0	2.2	1.6	1.3	1.0	6.0	4.4	3.2	2.4	1.9	1.5
		3.0	3.7	2.6	1.9	1.4	1.1	0.9	5.5	3.8	2.7	2.1	1.6	1.3



Simpler, Faster, Better

Table 3.5 Continued Lintels – Floors N16			Maximum floor load width (m) Reinforcement: N16											
Wall Type	Lintel Depth		500mm						600mm					
	LOADS (kPa)		Lintel Span (mm)						Lintel Span (mm)					
	DL	LL	1500	1800	2100	2400	2700	3000	1500	1800	2100	2400	2700	3000
ECOBLOCK 230	1.0	1.5	6.0	6.0	6.0	6.0	6.0	4.8	6.0	6.0	6.0	6.0	6.0	6.0
		2.0	6.0	6.0	6.0	6.0	5.0	4.0	6.0	6.0	6.0	6.0	6.0	5.1
		3.0	6.0	6.0	6.0	4.7	3.7	2.9	6.0	6.0	6.0	6.0	4.7	3.8
	4.8	1.5	6.0	6.0	4.4	3.4	2.6	2.1	6.0	6.0	5.6	4.3	3.3	2.7
		2.0	6.0	5.6	4.1	3.1	2.4	1.9	6.0	6.0	5.1	3.9	3.1	2.5
		3.0	6.0	4.8	3.5	2.6	2.0	1.6	6.0	6.0	4.4	3.3	2.6	2.1

ECOBLOCK 280	1.0	1.5	6.0	6.0	6.0	6.0	6.0	4.8	6.0	6.0	6.0	6.0	6.0	6.0
		2.0	6.0	6.0	6.0	6.0	5.0	4.0	6.0	6.0	6.0	6.0	6.0	5.2
		3.0	6.0	6.0	6.0	4.7	3.7	2.9	6.0	6.0	6.0	6.0	4.8	3.9
	4.8	1.5	6.0	6.0	4.4	3.4	2.6	2.1	6.0	6.0	5.7	4.4	3.4	2.7
		2.0	6.0	5.6	4.1	3.1	2.4	1.9	6.0	6.0	5.3	4.0	3.1	2.5
		3.0	6.0	4.8	3.5	2.6	2.0	1.6	6.0	6.0	4.5	3.4	2.7	2.1

ECOBLOCK 330	1.0	1.5	6.0	6.0	6.0	6.0	6.0	5.0	6.0	6.0	6.0	6.0	6.0	6.0
		2.0	6.0	6.0	6.0	6.0	5.1	4.1	6.0	6.0	6.0	6.0	6.0	5.3
		3.0	6.0	6.0	6.0	4.8	3.8	3.0	6.0	6.0	6.0	6.0	4.9	3.9
	4.8	1.5	6.0	6.0	4.6	3.4	2.7	2.1	6.0	6.0	5.8	4.4	3.5	2.8
		2.0	6.0	5.7	4.2	3.2	2.5	2.0	6.0	6.0	5.3	4.0	3.2	2.5
		3.0	6.0	4.9	3.6	2.7	2.1	1.7	6.0	6.0	4.5	3.4	2.7	2.2

Additional notes for table 3.5:

- Floor loads calculated as 1.2kPa dead load (timber or steel) and 4.8kPa dead load (200mm thick concrete slab)

- Floor load width is the floor width (or area) supported by the lintel per metre length of lintel beam



Simpler, Faster, Better

4.0 – Wall Bracing

Horizontal pressures exerted on a building by lateral loads such as wind or earthquakes need to be considered and allowed for in all structures. By using stiff construction perpendicular to the direction of loading, the loads can be transferred effectively through the structure and into the foundations. Solid concrete ECO-Block walls are a suitable stiff construction for this purpose.

All sections of wall continuous from foundation to roof or upper level may be considered as bracing walls as long as the wall panel length is at least 1/3 of the wall height.

In order for the floor & roof frames of buildings to effectively act as diaphragms and evenly distribute racking forces throughout the structure, bracing walls should be spaced evenly and in both orientations where possible throughout the building in accordance with maximum bracing wall guidelines in AS1684.2 & 3

4.1 – Applied Racking Forces

For the design purposes of this manual, racking forces in structures under consideration are to be determined in accordance with AS1684.2 & 3 Section 8 or AS4055 Wind Loading for Houses. Any structures outside the scope of this standard are to have the wind forces determined in accordance with AS1170.2 Wind Actions.

4.2 – Bracing Wall Capacities

The bracing wall capacity is calculated in accordance with AS3700 masonry structures, using the equations given for in-plane shear & out of plane shear.

Bracing Wall Capacities – In Plane

Table 4.1		Bracing Capacity (kN for given wall length)				
Orientation: Parallel To Wind	Reinforcing	N12				
		Wall Height (mm)				
	Wall length	2400	2700	3000	3300	3600
ECOBLOCK 230	1000	5.38	5.38	N/A	N/A	N/A
	2000	193	175	159	143	129
	3000	318	306	295	278	261
	4000	431	420	409	397	386
	5000	545	534	522	511	500
	6000	659	647	636	625	613
	7000	757	757	750	738	727
	8000	856	856	856	852	840
	9000	954	954	954	954	954
	10000	1053	1053	1053	1053	1053

ECOBLOCK 280	1000	12.2	12.2	N/A	N/A	N/A
	2000	262	238	216	195	174
	3000	444	427	410	387	364
	4000	615	598	581	564	547
	5000	786	769	752	735	718
	6000	957	940	923	906	889
	7000	1105	1105	1094	1077	1060
	8000	1253	1253	1253	1248	1231
	9000	1402	1402	1402	1402	1402
	10000	1550	1550	1550	1550	1550

ECOBLOCK 330	1000	21.7	21.7	N/A	N/A	N/A
	2000	331	301	274	247	220
	3000	570	547	525	496	468
	4000	799	776	753	730	707
	5000	1027	1004	981	958	936
	6000	1255	1233	1210	1187	1164
	7000	1453	1453	1438	1415	1392
	8000	1651	1651	1651	1644	1621
	9000	1849	1849	1849	1849	1849
	10000	2047	2047	2047	2047	2047

Additional notes for table 4.1:

- Minimum ratio of H/L is 0.4 since other design parameters will influence the failure of walls with geometry resulting in H/L as less than 0.4

- Anchorage/rocking motion does not govern failure for walls listed in the table. Engineering design of any walls not covered in the table should still do this check.



Simpler, Faster, Better

Bracing Wall Capacities – Out of Plane

Table 4.2		Bracing Capacity (kN for given wall length)									
Orientation: Perpendicular to Wind	Wind Rating	Reinforcing: N12									
		N2					N3				
		Wall Height (mm)					Wall Height (mm)				
		Wall length	2400	2700	3000	3300	3600	2400	2700	3000	3300
ECOBLOCK 230	1000	5.38	5.38	5.38	5.38	5.38	5.38	5.38	5.38	5.38	5.38
	2000	5.38	5.38	5.38	5.38	5.38	5.38	5.38	5.38	5.38	5.39
	3000	5.38	5.38	5.38	5.38	5.39	5.38	5.38	5.39	5.39	5.41
	4000	5.39	5.39	5.39	5.39	5.39	5.39	5.39	5.41	5.41	5.42
	5000	5.39	5.39	5.39	5.41	5.41	5.39	5.41	5.42	5.42	5.45
	6000	5.41	5.41	5.41	5.41	5.42	5.41	5.41	5.42	5.43	5.46
	7000	5.41	5.41	5.41	5.42	5.42	5.41	5.42	5.43	5.45	5.47
	8000	5.42	5.42	5.42	5.42	5.43	5.42	5.42	5.45	5.46	5.49
	9000	5.42	5.42	5.42	5.43	5.45	5.42	5.43	5.46	5.47	5.51
	10000	5.43	5.43	5.43	5.45	5.46	5.43	5.45	5.47	5.49	5.53

ECOBLOCK 280	1000	12.16	12.16	12.16	12.16	12.16	12.16	12.16	12.16	12.16	12.16
	2000	12.16	12.16	12.16	12.16	12.16	12.16	12.16	12.16	12.16	12.16
	3000	12.16	12.16	12.16	12.16	12.16	12.16	12.16	12.16	12.16	12.17
	4000	12.17	12.17	12.17	12.17	12.17	12.17	12.17	12.17	12.17	12.17
	5000	12.17	12.17	12.17	12.17	12.17	12.17	12.17	12.17	12.18	12.18
	6000	12.18	12.18	12.18	12.18	12.18	12.18	12.18	12.18	12.18	12.20
	7000	12.18	12.18	12.18	12.18	12.18	12.18	12.18	12.18	12.20	12.20
	8000	12.20	12.20	12.20	12.20	12.20	12.20	12.20	12.20	12.20	12.21
	9000	12.20	12.20	12.20	12.20	12.20	12.20	12.20	12.20	12.21	12.22
	10000	12.21	12.21	12.21	12.21	12.21	12.21	12.21	12.21	12.22	12.23

ECOBLOCK 330	1000	21.66	21.66	21.66	21.66	21.66	21.66	21.66	21.66	21.66	21.66
	2000	21.66	21.66	21.66	21.66	21.66	21.66	21.66	21.66	21.66	21.66
	3000	21.66	21.66	21.66	21.66	21.66	21.66	21.66	21.66	21.66	21.66
	4000	21.67	21.67	21.67	21.67	21.67	21.67	21.67	21.67	21.67	21.67
	5000	21.67	21.67	21.67	21.67	21.67	21.67	21.67	21.67	21.67	21.67
	6000	21.69	21.69	21.69	21.69	21.69	21.69	21.69	21.69	21.69	21.69
	7000	21.69	21.69	21.69	21.69	21.69	21.69	21.69	21.69	21.69	21.69
	8000	21.70	21.70	21.70	21.70	21.70	21.70	21.70	21.70	21.70	21.70
	9000	21.70	21.70	21.70	21.70	21.70	21.70	21.70	21.70	21.70	21.70
	10000	21.71	21.71	21.71	21.71	21.71	21.71	21.71	21.71	21.71	21.71



Simpler, Faster, Better

Table 4.2 Continued		Bracing Capacity (kN for given wall length)									
Orientation: Perpendicular to Wind		Reinforcing: N12									
	Wind Rating	N4/C1					N5/C2				
		Wall Height (mm)					Wall Height (mm)				
	Wall length	2400	2700	3000	3300	3600	2400	2700	3000	3300	3600
ECOBLOCK 230	1000	5.38	5.38	5.38	5.38	5.38	5.38	5.38	5.38	5.39	5.39
	2000	5.38	5.38	5.39	5.41	5.41	5.39	5.39	5.41	5.42	5.42
	3000	5.39	5.39	5.41	5.42	5.42	5.41	5.41	5.42	5.46	5.46
	4000	5.41	5.41	5.42	5.45	5.45	5.42	5.42	5.45	5.49	5.49
	5000	5.42	5.42	5.45	5.47	5.47	5.45	5.45	5.47	5.53	5.53
	6000	5.42	5.43	5.46	5.49	5.49	5.46	5.46	5.49	5.55	5.55
	7000	5.43	5.45	5.47	5.51	5.51	5.47	5.47	5.51	5.59	5.59
	8000	5.45	5.46	5.49	5.54	5.54	5.49	5.49	5.54	5.62	5.62
	9000	5.46	5.47	5.51	5.55	5.55	5.51	5.51	5.55	5.66	5.66
	10000	5.47	5.49	5.53	5.58	5.58	5.53	5.53	5.58	5.68	5.68

ECOBLOCK 280	1000	12.16	12.16	12.16	12.16	12.16	12.16	12.16	12.16	12.16	12.16
	2000	12.16	12.16	12.16	12.16	12.17	12.16	12.16	12.17	12.17	12.18
	3000	12.16	12.16	12.17	12.17	12.18	12.17	12.17	12.18	12.18	12.20
	4000	12.17	12.17	12.17	12.18	12.20	12.17	12.18	12.20	12.20	12.22
	5000	12.17	12.18	12.18	12.20	12.22	12.18	12.20	12.22	12.22	12.25
	6000	12.18	12.18	12.20	12.21	12.23	12.20	12.21	12.23	12.23	12.26
	7000	12.18	12.20	12.20	12.22	12.25	12.20	12.22	12.25	12.25	12.29
	8000	12.20	12.20	12.21	12.23	12.26	12.21	12.23	12.26	12.26	12.31
	9000	12.20	12.21	12.22	12.25	12.29	12.22	12.25	12.29	12.29	12.33
	10000	12.21	12.22	12.23	12.26	12.30	12.23	12.26	12.30	12.30	12.35

ECOBLOCK 330	1000	21.66	21.66	21.66	21.66	21.66	21.66	21.66	21.66	21.66	21.66
	2000	21.66	21.66	21.66	21.66	21.66	21.66	21.66	21.66	21.66	21.67
	3000	21.66	21.66	21.66	21.67	21.67	21.66	21.67	21.67	21.67	21.69
	4000	21.67	21.67	21.67	21.67	21.69	21.67	21.67	21.69	21.69	21.70
	5000	21.67	21.67	21.67	21.69	21.70	21.67	21.69	21.70	21.70	21.73
	6000	21.69	21.69	21.69	21.70	21.70	21.69	21.70	21.70	21.71	21.74
	7000	21.69	21.69	21.69	21.70	21.71	21.69	21.70	21.71	21.73	21.75
	8000	21.70	21.70	21.70	21.71	21.73	21.70	21.71	21.73	21.74	21.77
	9000	21.70	21.70	21.70	21.73	21.74	21.70	21.73	21.74	21.75	21.79
	10000	21.71	21.71	21.71	21.74	21.75	21.71	21.74	21.75	21.77	21.81



Simpler, Faster, Better

Table 4.2 Continued		Bracing Capacity (kN for given wall length)									
Orientation: Perpendicular to Wind		Reinforcing: N12									
	Wind Rating	N6/C3					C4				
		Wall Height (mm)					Wall Height (mm)				
	Wall length	2400	2700	3000	3300	3600	2400	2700	3000	3300	3600
ECOBLOCK 230	1000	5.38	5.39	5.39	N/A	N/A	5.39	N/A	N/A	N/A	N/A
	2000	5.41	5.42	5.42	N/A	N/A	5.42	N/A	N/A	N/A	N/A
	3000	5.42	5.46	5.46	N/A	N/A	5.46	N/A	N/A	N/A	N/A
	4000	5.45	5.49	5.49	N/A	N/A	5.49	N/A	N/A	N/A	N/A
	5000	5.47	5.53	5.53	N/A	N/A	5.53	N/A	N/A	N/A	N/A
	6000	5.49	5.55	5.55	N/A	N/A	5.55	N/A	N/A	N/A	N/A
	7000	5.51	5.59	5.59	N/A	N/A	5.59	N/A	N/A	N/A	N/A
	8000	5.54	5.62	5.62	N/A	N/A	5.62	N/A	N/A	N/A	N/A
	9000	5.55	5.66	5.66	N/A	N/A	5.66	N/A	N/A	N/A	N/A
	10000	5.58	5.68	5.68	N/A	N/A	5.68	N/A	N/A	N/A	N/A

ECOBLOCK 280	1000	12.16	12.16	12.16	N/A	N/A	12.16	12.16	N/A	N/A	N/A
	2000	12.16	12.17	12.18	N/A	N/A	12.17	12.18	N/A	N/A	N/A
	3000	12.17	12.18	12.20	N/A	N/A	12.18	12.20	N/A	N/A	N/A
	4000	12.18	12.20	12.22	N/A	N/A	12.20	12.22	N/A	N/A	N/A
	5000	12.20	12.22	12.25	N/A	N/A	12.22	12.25	N/A	N/A	N/A
	6000	12.21	12.23	12.26	N/A	N/A	12.23	12.26	N/A	N/A	N/A
	7000	12.22	12.25	12.29	N/A	N/A	12.25	12.29	N/A	N/A	N/A
	8000	12.23	12.26	12.31	N/A	N/A	12.26	12.31	N/A	N/A	N/A
	9000	12.25	12.29	12.33	N/A	N/A	12.29	12.33	N/A	N/A	N/A
	10000	12.26	12.30	12.35	N/A	N/A	12.30	12.35	N/A	N/A	N/A

ECOBLOCK 330	1000	21.66	21.66	21.66	N/A	N/A	21.66	21.66	N/A	N/A	N/A
	2000	21.66	21.66	21.67	N/A	N/A	21.66	21.67	N/A	N/A	N/A
	3000	21.67	21.67	21.69	N/A	N/A	21.67	21.69	N/A	N/A	N/A
	4000	21.67	21.69	21.70	N/A	N/A	21.69	21.70	N/A	N/A	N/A
	5000	21.69	21.70	21.73	N/A	N/A	21.70	21.73	N/A	N/A	N/A
	6000	21.70	21.71	21.74	N/A	N/A	21.71	21.74	N/A	N/A	N/A
	7000	21.70	21.73	21.75	N/A	N/A	21.73	21.75	N/A	N/A	N/A
	8000	21.71	21.74	21.77	N/A	N/A	21.74	21.77	N/A	N/A	N/A
	9000	21.73	21.75	21.79	N/A	N/A	21.75	21.79	N/A	N/A	N/A
	10000	21.74	21.77	21.81	N/A	N/A	21.77	21.81	N/A	N/A	N/A

Additional notes for table 4.2:

- Values from this table cannot be used without a minimum amount of bracing in the other orientation (Refer spacing criteria in AS1684)



Simpler, Faster, Better

Table 4.2a		Bracing Capacity (kN for given wall length)									
Orientation: Perpendicular to Wind	Reinforcing: N16										
	Wind Rating	N2					N3				
		Wall Height (mm)					Wall Height (mm)				
	Wall length	2400	2700	3000	3300	3600	2400	2700	3000	3300	3600
ECOBLOCK 230	1000	10.63	10.63	10.63	10.63	10.63	10.63	10.63	10.63	10.63	10.63
	2000	10.63	10.63	10.63	10.63	10.63	10.63	10.63	10.63	10.63	10.63
	3000	10.63	10.63	10.63	10.63	10.63	10.63	10.63	10.63	10.63	13.27
	4000	13.27	13.27	13.27	13.27	13.27	13.27	13.27	13.27	13.27	13.27
	5000	13.27	13.27	13.27	13.27	13.27	13.27	13.27	13.27	13.27	15.91
	6000	15.91	15.91	15.91	15.91	15.91	15.91	15.91	15.91	15.91	18.55
	7000	15.91	15.91	15.91	15.91	15.91	15.91	15.91	15.91	15.91	18.55
	8000	18.55	18.55	18.55	18.55	18.55	18.55	18.55	18.55	18.55	21.18
	9000	18.55	18.55	18.55	18.55	18.55	18.55	18.55	18.55	18.55	23.82
	10000	21.18	21.18	21.18	21.18	21.18	21.18	21.18	21.18	21.18	26.46

ECOBLOCK 280	1000	17.41	17.41	17.41	17.41	17.41	17.41	17.41	17.41	17.41	17.41
	2000	17.41	17.41	17.41	17.41	17.41	17.41	17.41	17.41	17.41	17.41
	3000	17.41	17.41	17.41	17.41	17.41	17.41	17.41	17.41	17.41	17.41
	4000	20.04	20.04	20.04	20.04	20.04	20.04	20.04	20.04	20.04	20.04
	5000	20.04	20.04	20.04	20.04	20.04	20.04	20.04	20.04	20.04	20.04
	6000	22.68	22.68	22.68	22.68	22.68	22.68	22.68	22.68	22.68	22.68
	7000	22.68	22.68	22.68	22.68	22.68	22.68	22.68	22.68	22.68	22.68
	8000	25.32	25.32	25.32	25.32	25.32	25.32	25.32	25.32	25.32	25.32
	9000	25.32	25.32	25.32	25.32	25.32	25.32	25.32	25.32	25.32	25.32
	10000	27.96	27.96	27.96	27.96	27.96	27.96	27.96	27.96	27.96	27.96

ECOBLOCK 330	1000	26.91	26.91	26.91	26.91	26.91	26.91	26.91	26.91	26.91	26.91
	2000	26.91	26.91	26.91	26.91	26.91	26.91	26.91	26.91	26.91	26.91
	3000	26.91	26.91	26.91	26.91	26.91	26.91	26.91	26.91	26.91	26.91
	4000	29.55	29.55	29.55	29.55	29.55	29.55	29.55	29.55	29.55	29.55
	5000	29.55	29.55	29.55	29.55	29.55	29.55	29.55	29.55	29.55	29.55
	6000	32.19	32.19	32.19	32.19	32.19	32.19	32.19	32.19	32.19	32.19
	7000	32.19	32.19	32.19	32.19	32.19	32.19	32.19	32.19	32.19	32.19
	8000	34.83	34.83	34.83	34.83	34.83	34.83	34.83	34.83	34.83	34.83
	9000	34.83	34.83	34.83	34.83	34.83	34.83	34.83	34.83	34.83	34.83
	10000	37.46	37.46	37.46	37.46	37.46	37.46	37.46	37.46	37.46	37.46



Simpler, Faster, Better

Table 4.2a Continued		Bracing Capacity (kN for given wall length)									
Orientation: Perpendicular to Wind	Wind Rating	N4/C1					N5/C2				
		Wall Height (mm)					Wall Height (mm)				
	Wall length	2400	2700	3000	3300	3600	2400	2700	3000	3300	3600
	ECOBLOCK 230	1000	10.63	10.63	10.63	10.63	10.63	10.63	10.63	10.63	10.63
	2000	10.63	10.63	10.63	10.63	10.63	10.63	10.63	10.63	13.27	15.91
	3000	10.63	10.63	13.27	13.27	13.27	13.27	13.27	13.27	15.91	18.55
	4000	13.27	13.27	13.27	15.91	15.91	13.27	15.91	15.91	18.55	23.82
	5000	13.27	13.27	15.91	18.55	18.55	15.91	18.55	18.55	23.82	29.10
	6000	15.91	15.91	18.55	18.55	21.18	18.55	18.55	21.18	26.46	31.74
	7000	15.91	15.91	18.55	21.18	23.82	18.55	21.18	23.82	29.10	37.01
	8000	18.55	18.55	21.18	23.82	26.46	21.18	23.82	26.46	31.74	42.29
	9000	18.55	18.55	23.82	26.46	29.10	23.82	26.46	29.10	37.01	44.93
	10000	21.18	21.18	26.46	29.10	31.74	26.46	29.10	31.74	39.65	50.20

ECOBLOCK 280	1000	17.41	17.41	17.41	17.41	17.41	17.41	17.41	17.41	17.41	17.41
	2000	17.41	17.41	17.41	17.41	17.41	17.41	17.41	17.41	17.41	17.41
	3000	17.41	17.41	17.41	17.41	17.41	17.41	17.41	17.41	20.04	20.04
	4000	20.04	20.04	20.04	20.04	20.04	20.04	20.04	20.04	22.68	22.68
	5000	20.04	20.04	20.04	20.04	22.68	20.04	20.04	22.68	25.32	25.32
	6000	22.68	22.68	22.68	22.68	22.68	22.68	22.68	22.68	25.32	27.96
	7000	22.68	22.68	22.68	22.68	25.32	22.68	22.68	25.32	27.96	30.60
	8000	25.32	25.32	25.32	25.32	25.32	25.32	25.32	25.32	30.60	33.23
	9000	25.32	25.32	25.32	25.32	27.96	25.32	25.32	27.96	33.23	35.87
	10000	27.96	27.96	27.96	27.96	30.60	27.96	27.96	30.60	35.87	38.51

ECOBLOCK 330	1000	26.91	26.91	26.91	26.91	26.91	26.91	26.91	26.91	26.91	26.91
	2000	26.91	26.91	26.91	26.91	26.91	26.91	26.91	26.91	26.91	26.91
	3000	26.91	26.91	26.91	26.91	26.91	26.91	26.91	26.91	26.91	26.91
	4000	29.55	29.55	29.55	29.55	29.55	29.55	29.55	29.55	29.55	29.55
	5000	29.55	29.55	29.55	29.55	29.55	29.55	29.55	29.55	29.55	32.19
	6000	32.19	32.19	32.19	32.19	32.19	32.19	32.19	32.19	32.19	32.19
	7000	32.19	32.19	32.19	32.19	32.19	32.19	32.19	32.19	32.19	34.83
	8000	34.83	34.83	34.83	34.83	34.83	34.83	34.83	34.83	34.83	34.83
	9000	34.83	34.83	34.83	34.83	34.83	34.83	34.83	34.83	34.83	37.46
	10000	37.46	37.46	37.46	37.46	37.46	37.46	37.46	37.46	37.46	40.10



Simpler, Faster, Better

Table 4.2a Continued		Bracing Capacity (kN for given wall length)									
Orientation: Perpendicular to Wind		Reinforcing: N16									
	Wind Rating	N6/C3					C4				
		Wall Height (mm)					Wall Height (mm)				
	Wall length	2400	2700	3000	3300	3600	2400	2700	3000	3300	3600
ECOBLOCK 230	1000	10.63	10.63	10.63	10.63	13.27	10.63	10.63	13.27	13.27	N/A
	2000	10.63	13.27	15.91	15.91	18.55	13.27	15.91	18.55	18.55	N/A
	3000	13.27	15.91	18.55	18.55	26.46	15.91	18.55	26.46	26.46	N/A
	4000	15.91	18.55	23.82	23.82	31.74	18.55	23.82	31.74	31.74	N/A
	5000	18.55	23.82	29.10	29.10	39.65	23.82	29.10	39.65	39.65	N/A
	6000	21.18	26.46	31.74	31.74	44.93	26.46	31.74	44.93	44.93	N/A
	7000	23.82	29.10	37.01	37.01	52.84	29.10	37.01	52.84	52.84	N/A
	8000	26.46	31.74	42.29	42.29	58.12	31.74	42.29	58.12	58.12	N/A
	9000	29.10	37.01	44.93	44.93	66.03	37.01	44.93	66.03	66.03	N/A
	10000	31.74	39.65	50.20	50.20	71.31	39.65	50.20	71.31	71.31	N/A

ECOBLOCK 280	1000	17.41	17.41	17.41	17.41	17.41	17.41	17.41	17.41	17.41	17.41
	2000	17.41	17.41	17.41	20.04	22.68	17.41	17.41	20.04	22.68	22.68
	3000	17.41	20.04	20.04	22.68	25.32	20.04	20.04	22.68	25.32	25.32
	4000	20.04	20.04	22.68	25.32	30.60	20.04	22.68	25.32	30.60	30.60
	5000	20.04	22.68	25.32	30.60	35.87	22.68	25.32	30.60	35.87	35.87
	6000	22.68	25.32	25.32	33.23	38.51	25.32	27.96	33.23	38.51	38.51
	7000	22.68	25.32	27.96	35.87	43.79	25.32	30.60	35.87	43.79	43.79
	8000	25.32	27.96	30.60	38.51	49.06	27.96	33.23	38.51	49.06	49.06
	9000	25.32	30.60	33.23	43.79	51.70	30.60	35.87	43.79	51.70	51.70
	10000	27.96	33.23	35.87	46.43	56.98	33.23	38.51	46.43	56.98	56.98

ECOBLOCK 330	1000	26.91	26.91	26.91	26.91	26.91	26.91	26.91	26.91	26.91	26.91
	2000	26.91	26.91	26.91	26.91	26.91	26.91	26.91	26.91	26.91	29.55
	3000	26.91	26.91	26.91	29.55	29.55	26.91	29.55	29.55	29.55	32.19
	4000	29.55	29.55	29.55	29.55	32.19	29.55	29.55	32.19	32.19	34.83
	5000	29.55	29.55	32.19	32.19	34.83	29.55	32.19	34.83	34.83	40.10
	6000	32.19	32.19	32.19	34.83	37.46	32.19	34.83	34.83	37.46	42.74
	7000	32.19	32.19	34.83	34.83	40.10	32.19	34.83	37.46	40.10	45.38
	8000	34.83	34.83	34.83	37.46	42.74	34.83	37.46	40.10	42.74	48.02
	9000	34.83	34.83	37.46	40.10	45.38	34.83	40.10	42.74	45.38	53.29
	10000	37.46	37.46	40.10	42.74	48.02	37.46	42.74	45.38	48.02	55.93

Additional notes for table 4.2a:

- Values from this table cannot be used without a minimum amount of bracing in the other orientation (Refer spacing criteria in AS1684)



Simpler, Faster, Better

4.3 – Further Design Considerations for Bracing Walls

When using internal ECO-Block walls as bracing panels; vertical reinforcement shall be placed 100mm from the wall ends & at 1200mm centres in between.

Walls shall be reinforced at the top in the form of a bond beam as per detail 1.5b. If the bracing wall panel is greater than 3 metres high, one additional N12 horizontal reinforcing bar at the wall mid height is required. Cog ends 450 and lap to vertical wall reinforcement at each end of bracing wall panel.

Internal or nib walls shall be tied back to external ECO-Block building or party walls as per detail 1.5f.

No plumbing penetrations should be made through internal & external bracing portions of wall.

Care should be taken to ensure starter bars from footings are lapped and securely tied to each vertical reinforcing bar in bracing wall.

5.0 Basement Walls & Retaining Walls

ECO-Block walls are ideal for basement & lower level partially subterranean structures since the polystyrene form offers an effective waterproofing to the exterior wall face. The reinforcement can be kept to a minimum by securing the top of the wall to a ground floor concrete slab.

Retaining walls can also be constructed out of ECO-Block using a cantilever footing design. When designing retaining walls, it is best to use AS3600 Concrete Structures & AS4678 Earth Retaining Structures as reference.

5.1 - Waterproofing & Drainage

Despite the polystyrene being effectively waterproof, a tanking layer should still be applied to the back face of the retaining wall structure when used in basement applications. This is to ensure compliance with the BCA and provide little or no moisture ingress into the basement room. Where the retaining walls are used as an external structure, no waterproofing or tanking is required.

5.2 - Standard Retaining Walls

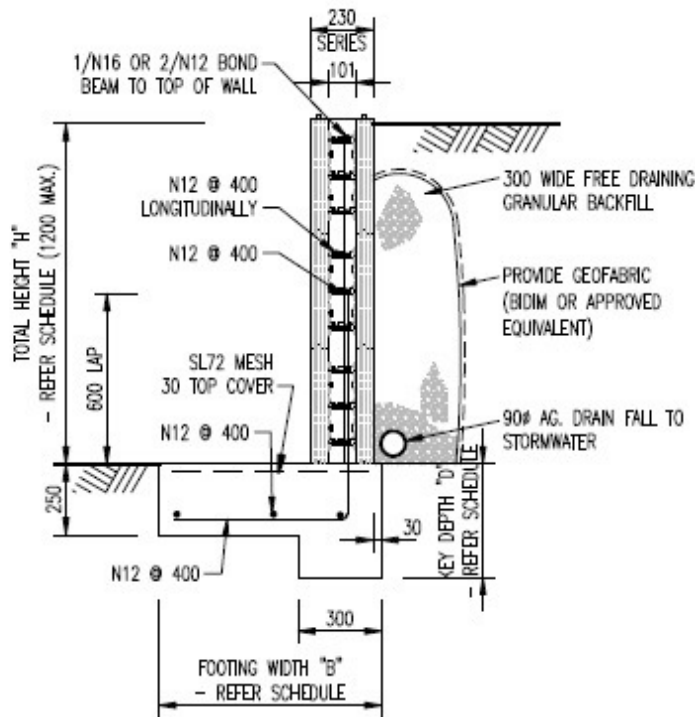

DIMENSION SCHEDULE
400-1200 HIGH RETAINING WALL

WALL HEIGHT "H"	FOOTING WIDTH "B"	KEY DEPTH "D"
400	400	250
800	600	350
1200	800	400

Fig 5.2a 400 – 1200 High Retaining Wall (230 Series Panels) Low Side Footing

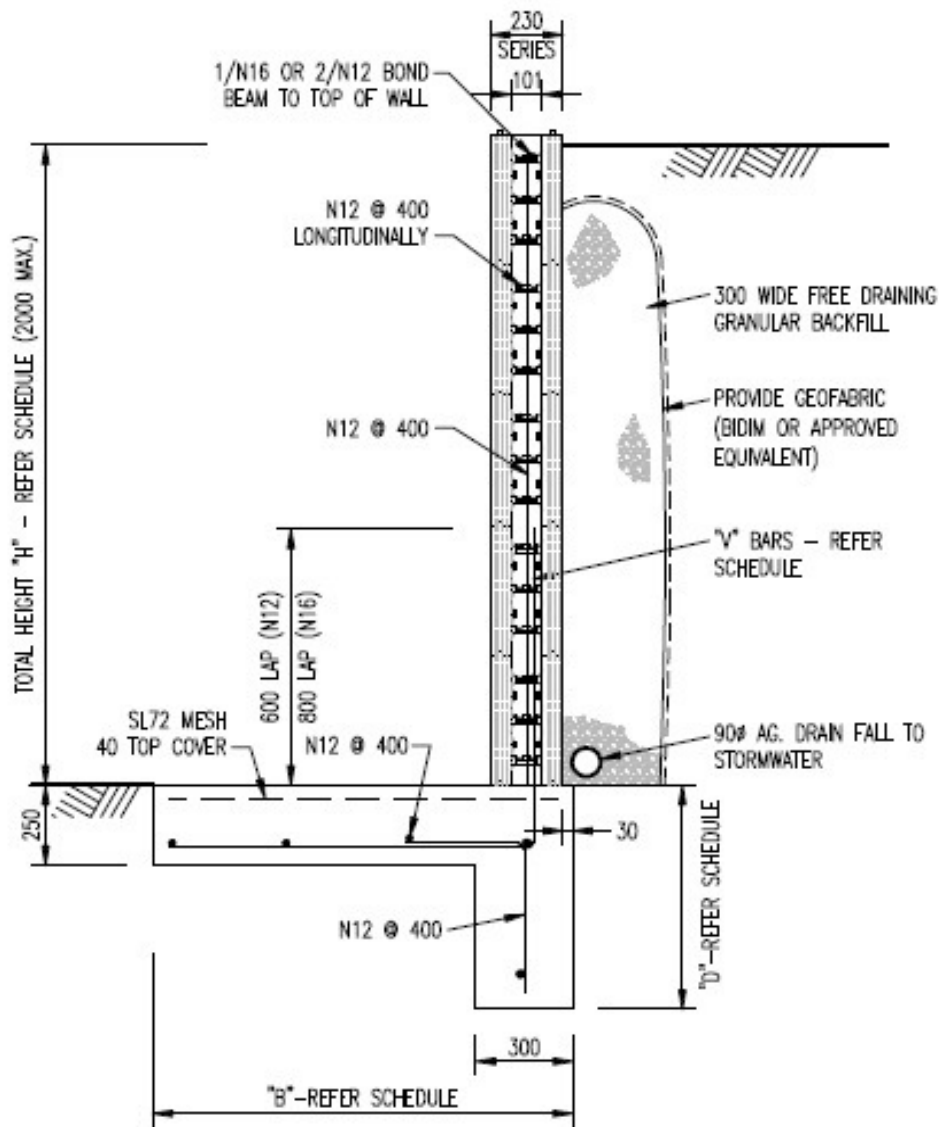

DIMENSION & REINFORCING SCHEDULE

1200-2000 HIGH RETAINING WALL

WALL HEIGHT "H"	FOOTING WIDTH "B"	KEY DEPTH "D"	V BARS
1200	800	400	N12 @ 400
1600	1100	550	N12 @ 200
2000	1400	700	N16 @ 200

Fig 5.2b 1200 – 2000 High Retaining Wall (230 Series Panels) Low Side Footing

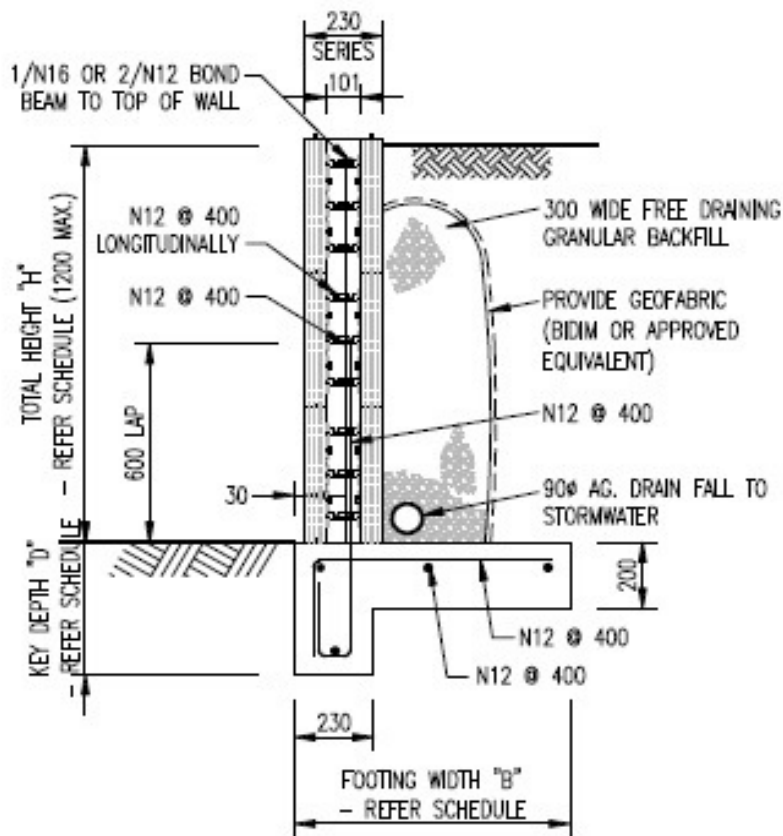

DIMENSION SCHEDULE
400-1200 HIGH RETAINING WALL

WALL HEIGHT "H"	FOOTING WIDTH "B"	KEY DEPTH "D"
400	400	250
800	600	350
1200	800	400

Fig 5.2c 400 – 1200 High Retaining Wall (230 Series Panels) High Side Footing

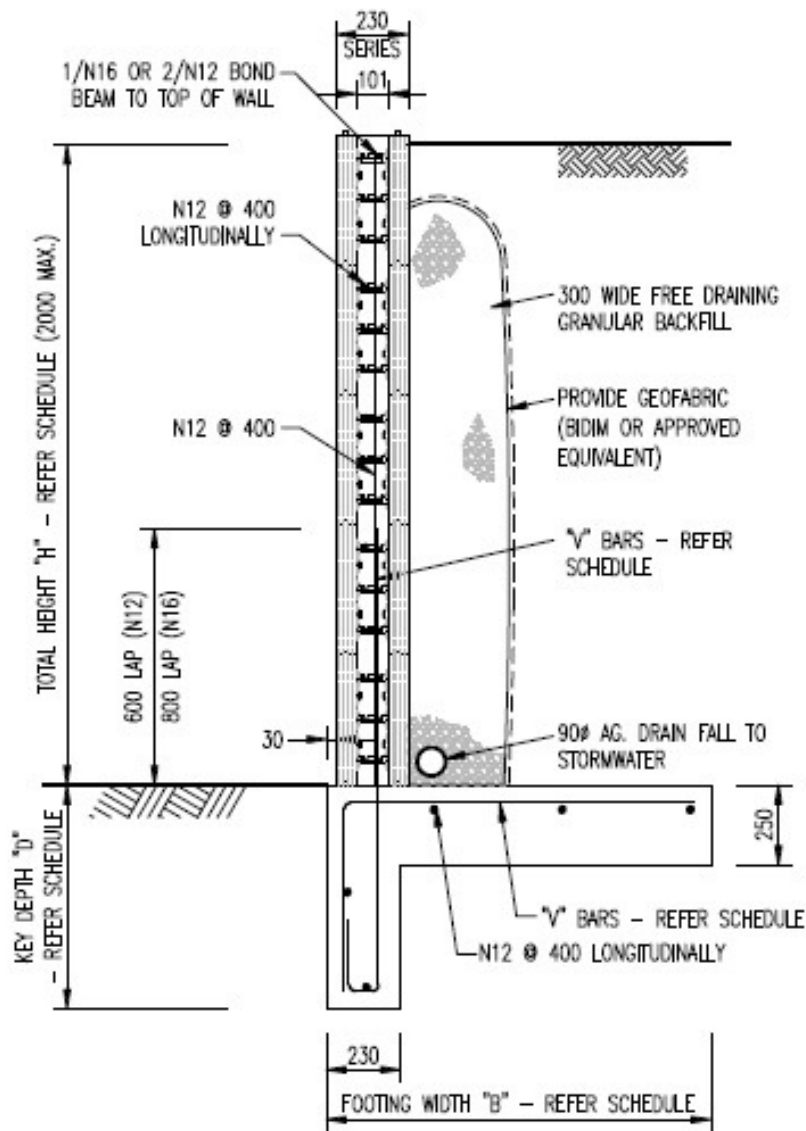

DIMENSION & REINFORCING SCHEDULE

1200-2000 HIGH RETAINING WALL

WALL HEIGHT "H"	FOOTING WIDTH "B"	KEY DEPTH "D"	V BARS
1200	800	400	N12 @ 400
1600	1000	550	N12 @ 200
2000	1200	700	N16 @ 200

Fig 5.2d 1200 – 2000 High Retaining Wall (230 Series Panels) High Side Footing

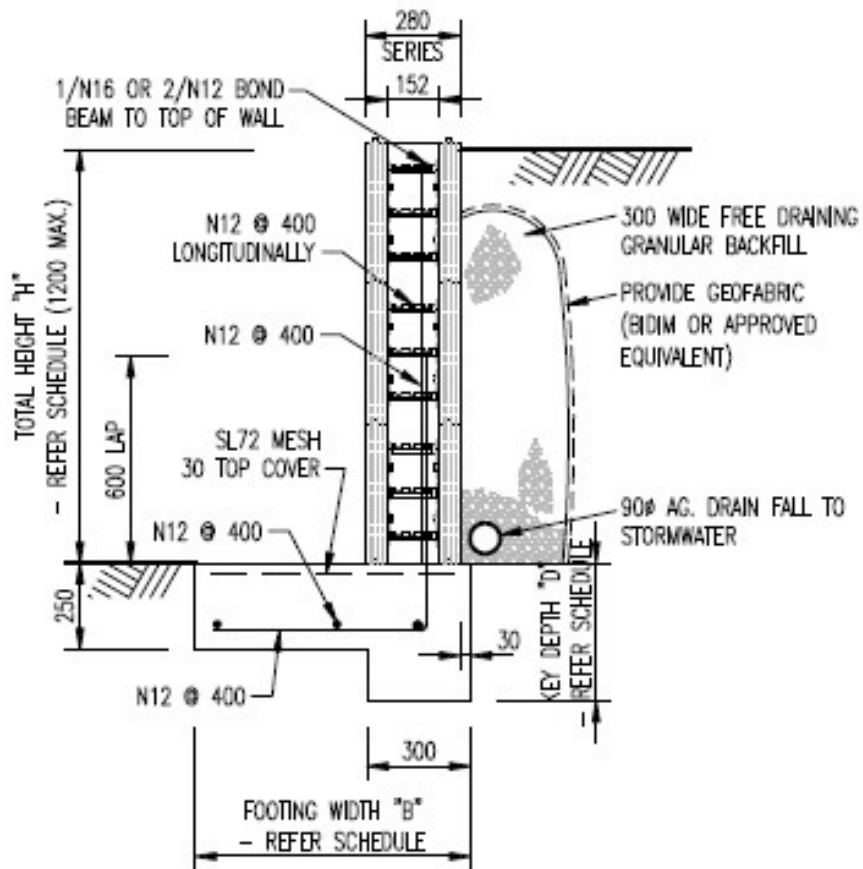

DIMENSION SCHEDULE
400-1200 HIGH RETAINING WALL

WALL HEIGHT "H"	FOOTING WIDTH "B"	KEY DEPTH "D"
400	400	250
800	600	350
1200	800	400

Fig 5.2e 400 – 1200 High Retaining Wall (280 Series Panels) Low Side Footing

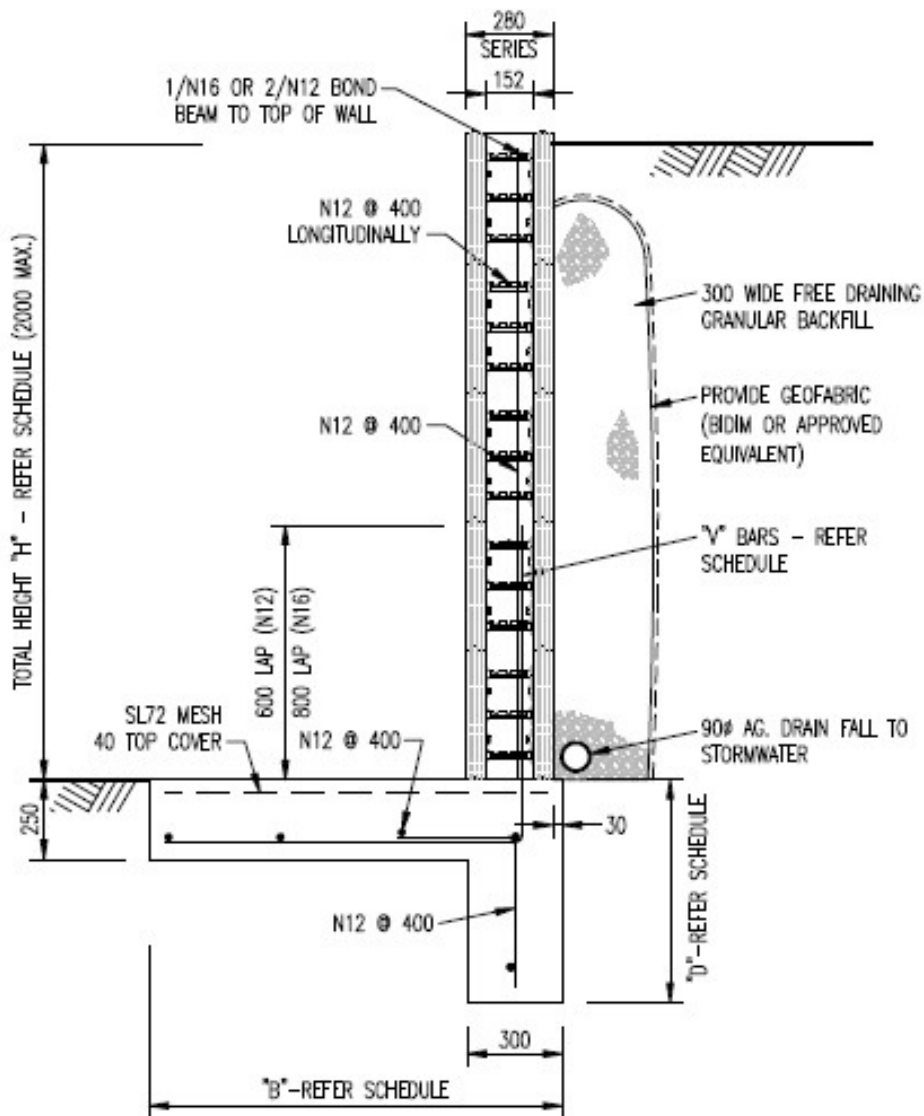

DIMENSION & REINFORCING SCHEDULE

1200-2000 HIGH RETAINING WALL

WALL HEIGHT "H"	FOOTING WIDTH "B"	KEY DEPTH "D"	V BARS
1200	800	400	N12 @ 400
1600	1100	550	N12 @ 300
2000	1400	700	N12 @ 200

Fig 5.2f 1200 – 2000 High Retaining Wall (280 Series Panels) Low Side Footing

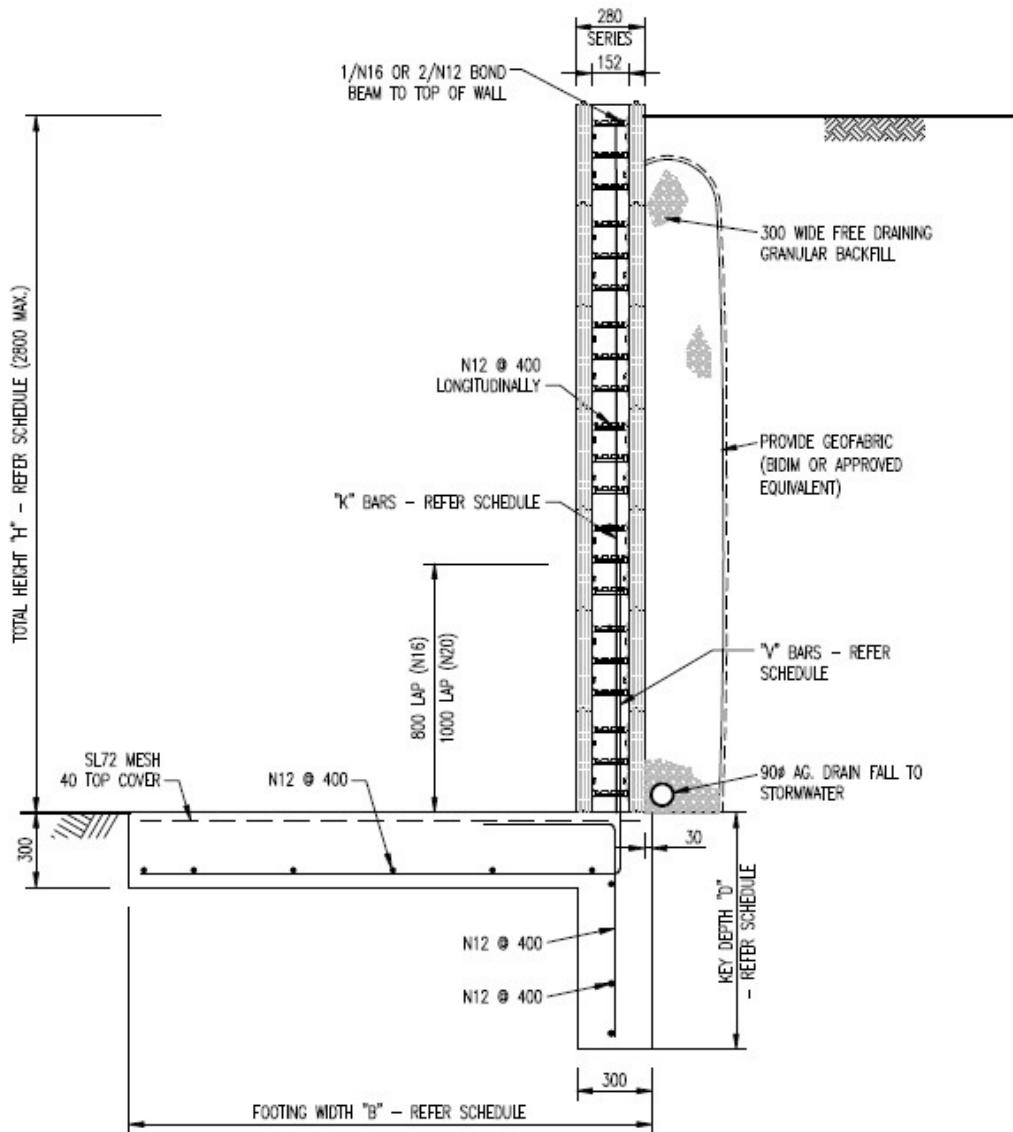

DIMENSION & REINFORCING SCHEDULE

2000-2800 HIGH RETAINING WALL

WALL HEIGHT "H"	FOOTING WIDTH "B"	KEY DEPTH "D"	"V" BARS	"K" BARS
2000	1400	700	N12 @ 200	N12 @ 200
2400	1700	800	N16 @ 200	N16 @ 200
2800	2100	950	N20 @ 200	N16 @ 200

Fig 5.2g 2000 – 2800 High Retaining Wall (280 Series Panels) Low Side Footing

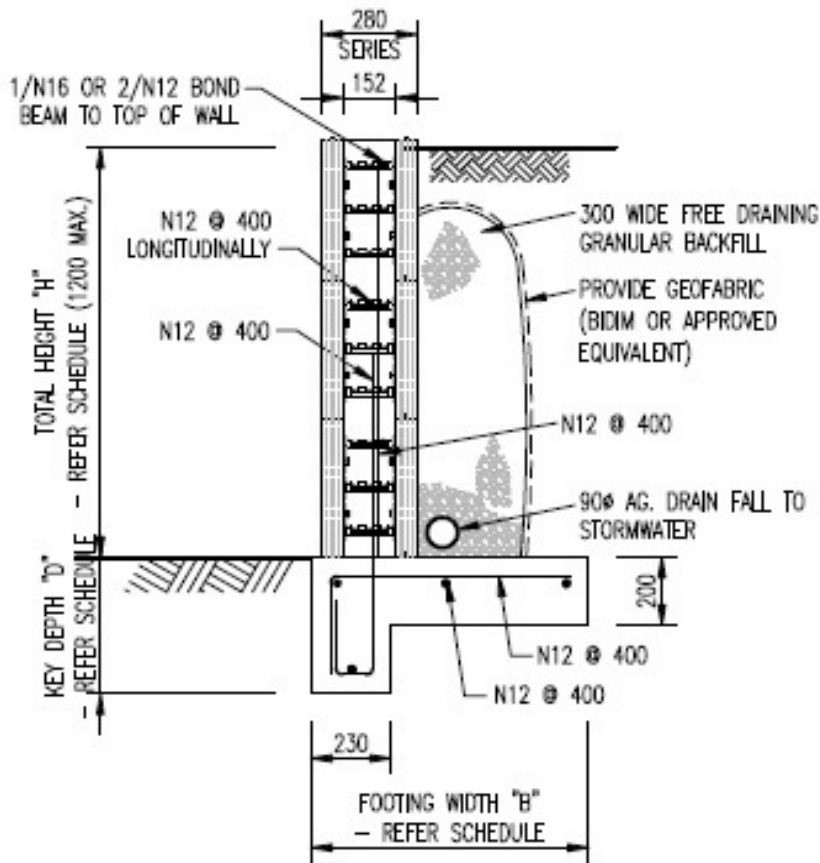

DIMENSION SCHEDULE
400-1200 HIGH RETAINING WALL

WALL HEIGHT "H"	FOOTING WIDTH "B"	KEY DEPTH "D"
400	400	250
800	600	350
1200	800	400

Fig 5.2h 400 – 1200 High Retaining Wall (280 Series Panels) High Side Footing

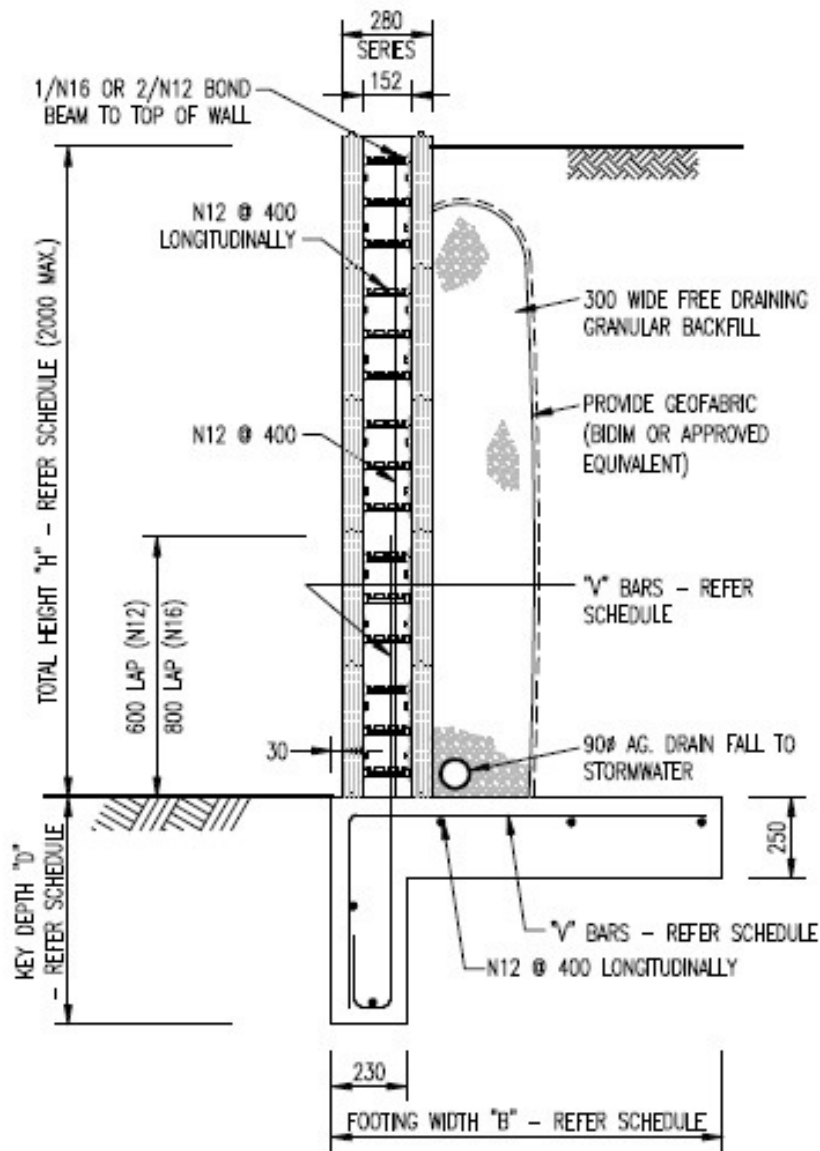

DIMENSION & REINFORCING SCHEDULE
1200-2000 HIGH RETAINING WALL

WALL HEIGHT "H"	FOOTING WIDTH "B"	KEY DEPTH "D"	"V" BARS
1200	800	400	N12 @ 400
1600	1000	550	N12 @ 200
2000	1200	700	N16 @ 200

Fig 5.2i 1200 – 2000 High Retaining Wall (280 Series Panels) High Side Footing

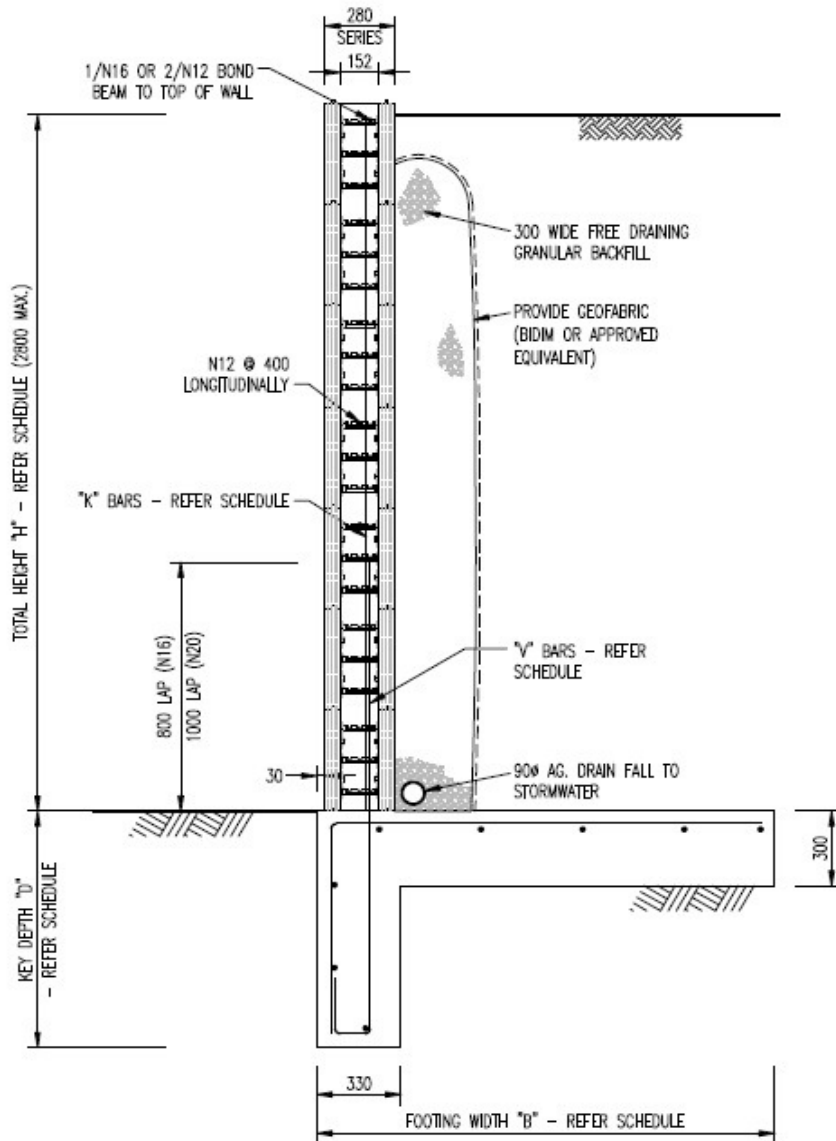

DIMENSION & REINFORCING SCHEDULE
2000-2800 HIGH RETAINING WALL

WALL HEIGHT "H"	FOOTING WIDTH "B"	KEY DEPTH "D"	"V" BARS	"K" BARS
2000	1200	700	N12 @ 200	N12 @ 200
2400	1500	800	N16 @ 200	N16 @ 200
2800	1800	950	N20 @ 200	N16 @ 200

Fig 5.2j 2000 – 2800 High Retaining Wall (280 Series Panels) High Side Footing

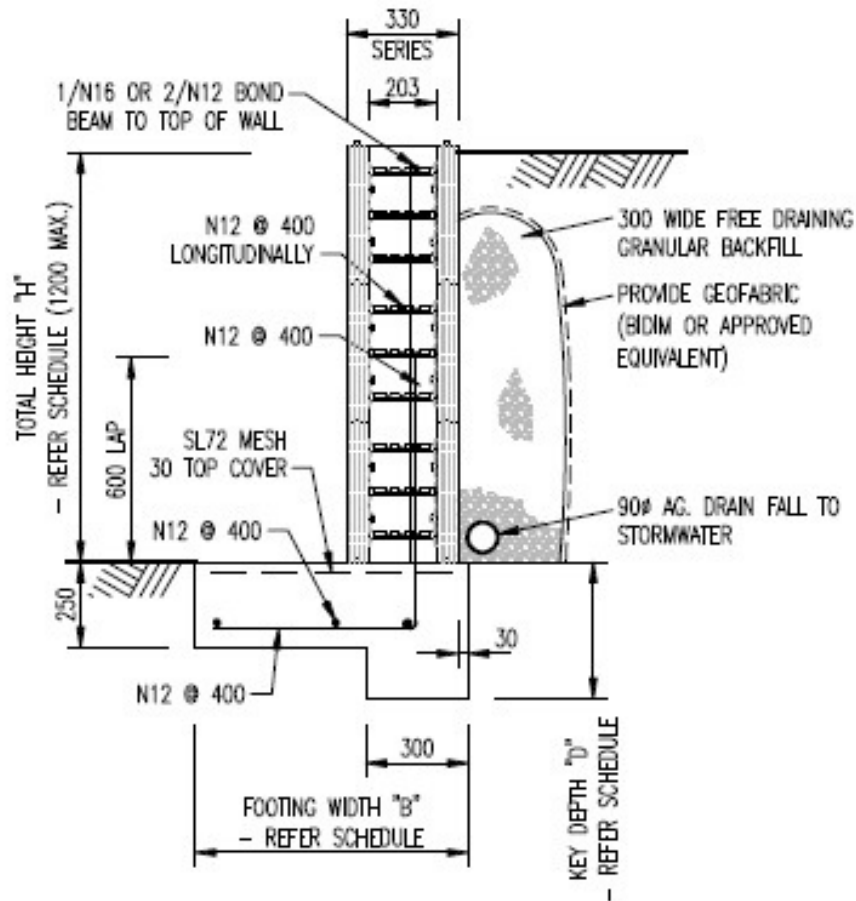

DIMENSION SCHEDULE

400-1200 HIGH RETAINING WALL

WALL HEIGHT "H"	FOOTING WIDTH "B"	KEY DEPTH "D"
400	400	250
800	600	350
1200	800	400

Fig 5.2k 400 – 1200 High Retaining Wall (330 Series Panels) Low Side Footing

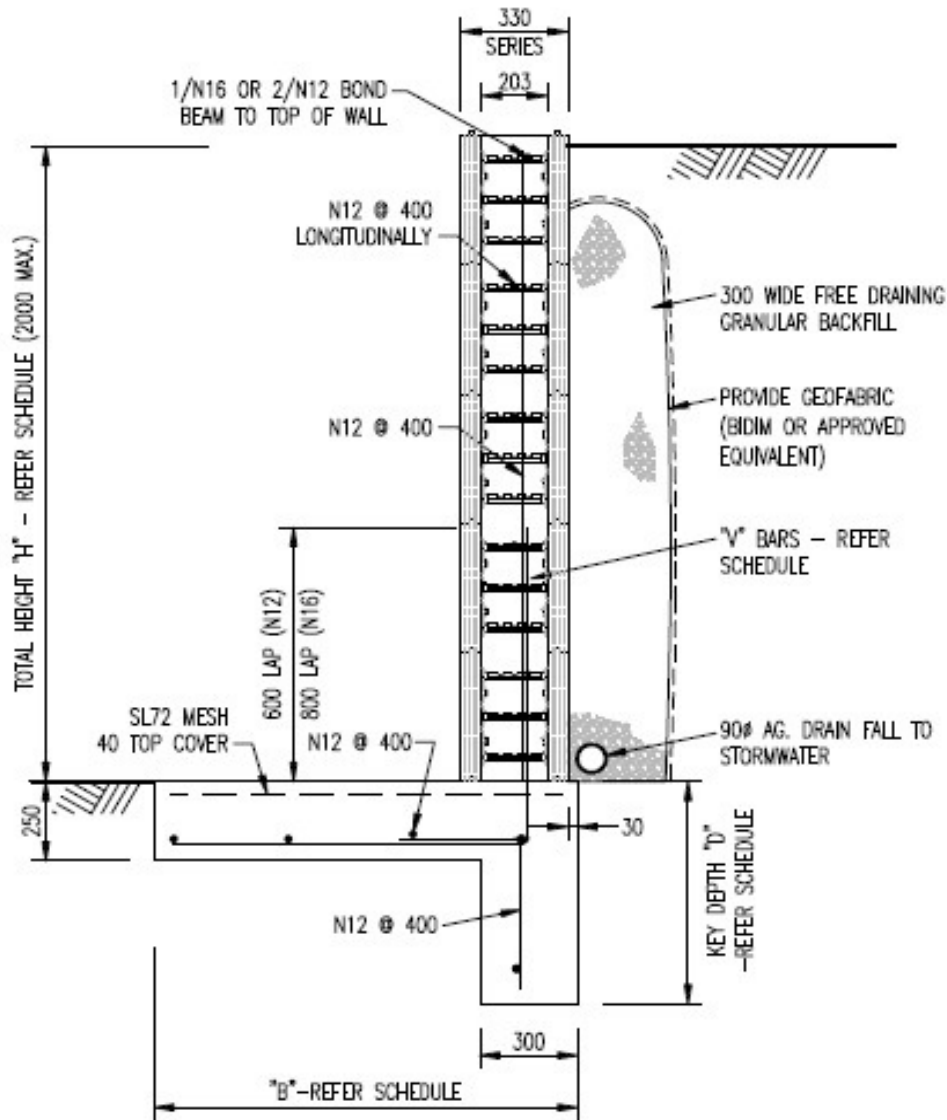

DIMENSION & REINFORCING SCHEDULE
1200-2000 HIGH RETAINING WALL

WALL HEIGHT "H"	FOOTING WIDTH "B"	KEY DEPTH "D"	"V" BARS
1200	800	400	N12 @ 400
1600	1100	550	N12 @ 300
2000	1400	700	N12 @ 200

Fig 5.21 1200 – 2000 High Retaining Wall (330 Series Panels) Low Side Footing

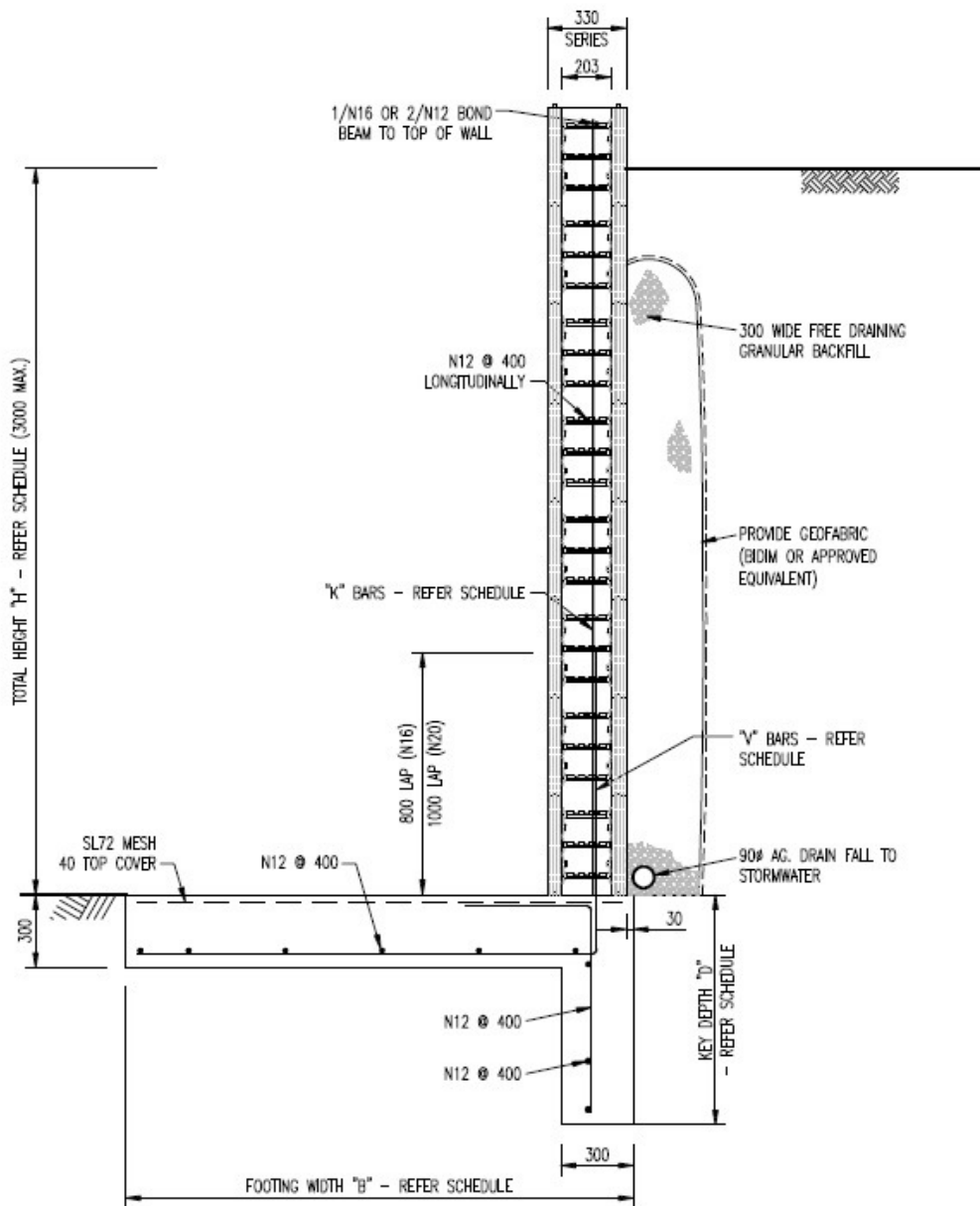

DIMENSION & REINFORCING SCHEDULE
2000-3000 HIGH RETAINING WALL

WALL HEIGHT "H"	FOOTING WIDTH "B"	KEY DEPTH "D"	"V" BARS	"K" BARS
2000	1400	700	N12 @ 200	N12 @ 200
2400	1700	800	N16 @ 200	N16 @ 200
2800	2100	950	N20 @ 200	N16 @ 200
3000	2300	1000	N20 @ 200	N16 @ 200

Fig 5.2m 2000 – 2800 High Retaining Wall (330 Series Panels) Low Side Footing

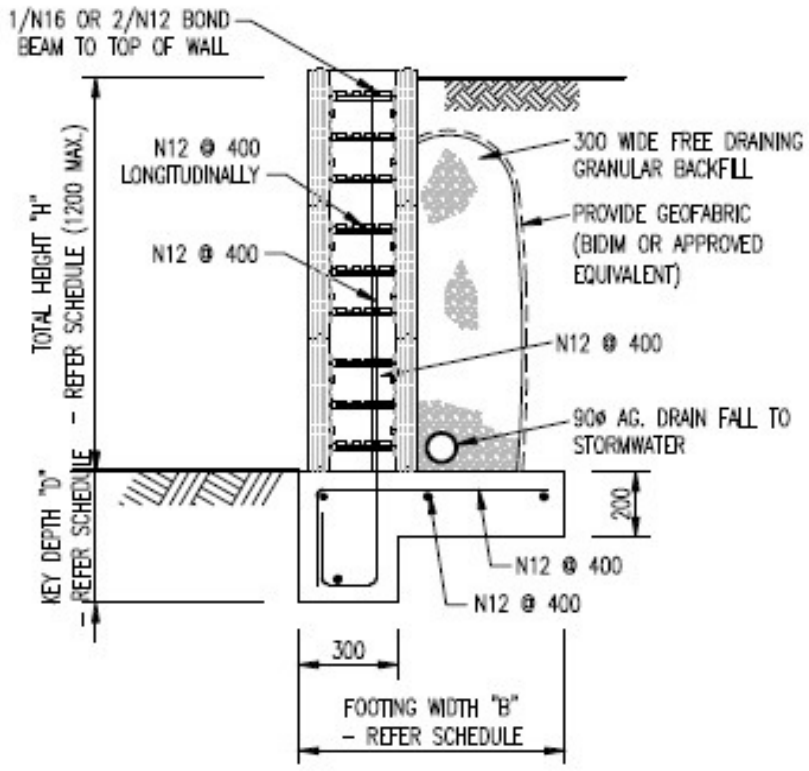

DIMENSION SCHEDULE
400-1200 HIGH RETAINING WALL

WALL HEIGHT "H"	FOOTING WIDTH "B"	KEY DEPTH "D"
400	400	250
800	600	350
1200	800	400

Fig 5.2n 400 – 1200 High Retaining Wall (330 Series Panels) High Side Footing

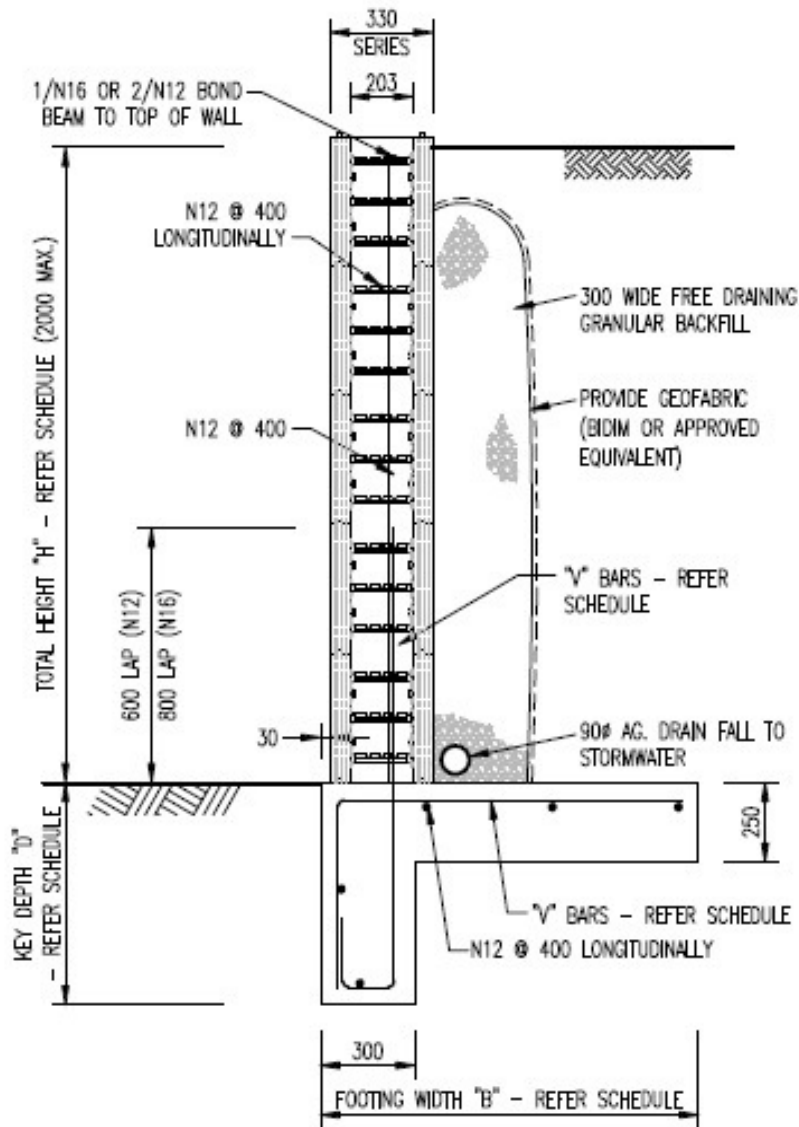

DIMENSION & REINFORCING SCHEDULE

1200-2000 HIGH RETAINING WALL

WALL HEIGHT "H"	FOOTING WIDTH "B"	KEY DEPTH "D"	"V" BARS
1200	800	400	N12 @ 400
1600	1000	550	N12 @ 200
2000	1200	700	N16 @ 200

Fig 5.2o 1200 – 2000 High Retaining Wall (330 Series Panels) High Side Footing

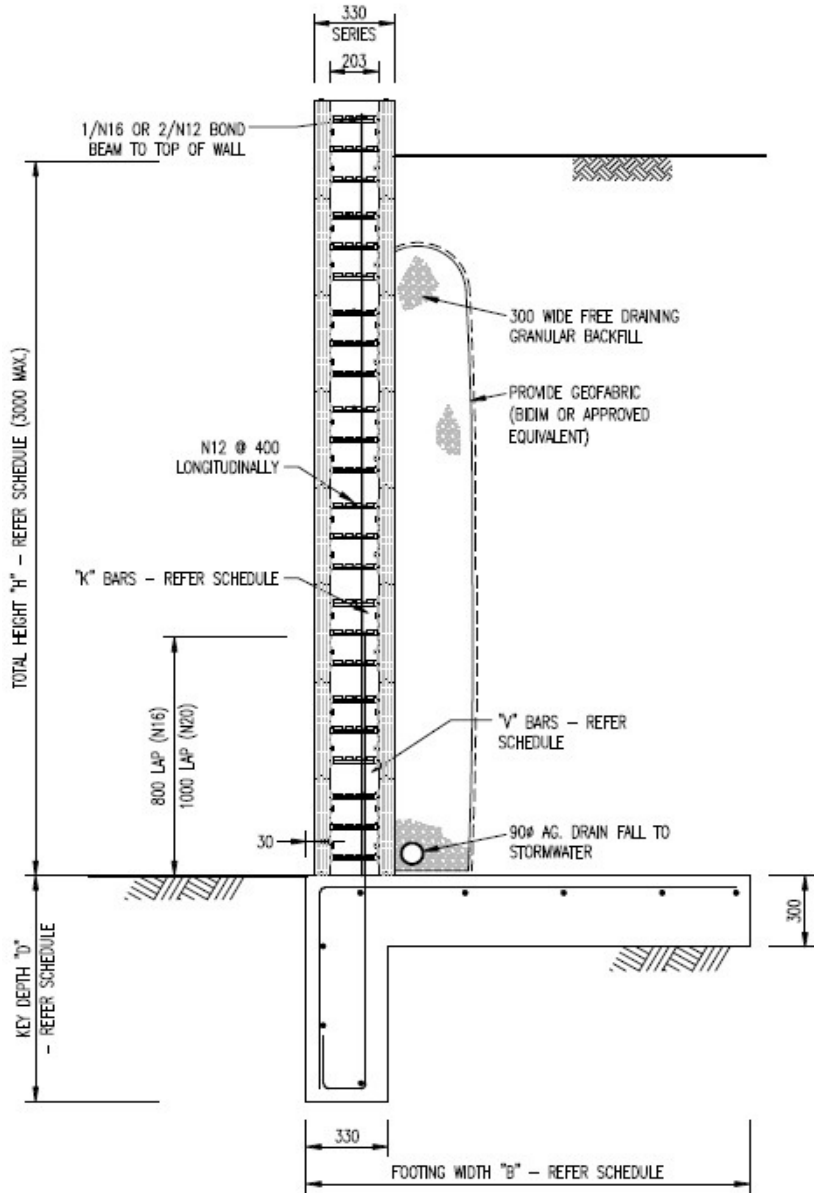

DIMENSION & REINFORCING SCHEDULE
2000-3000 HIGH RETAINING WALL

WALL HEIGHT "h"	FOOTING WIDTH "b"	KEY DEPTH "d"	"V" BARS	"K" BARS
2000	1200	700	N12 @ 200	N12 @ 200
2400	1500	800	N16 @ 200	N16 @ 200
2800	1800	950	N20 @ 200	N16 @ 200
3000	2000	1000	N20 @ 200	N16 @ 200

Fig 5.2p 2000 – 2800 High Retaining Wall (330 Series Panels) High Side Footing

Additional notes for the above figures 5.2a-5.2p:

- The above designs do not take into account the stiffness effects when the wall is laterally supported at the top by concrete slab or framed floor.
- When the top of the wall is unsupported, vertical reinforcement & footing starter bars should ideally be located towards the earth face of the wall although allowance in the design has been made if the bars are placed centrally. Alternatively, vertical reinforcement should be located towards the open face of the wall when it is supported at the top laterally by a floor or roof membrane.
- It is the responsibility of the engineer or designer to determine whether the wall should be reinforced nearest the open face or earth face if there is a considerable delay between construction of the retaining walls and the floor or roof above them.
- Assumed design parameters for the retaining walls are:

$$\gamma_{soil} = 18 \text{ kN/m}^3$$

$$\gamma_{conc} = 24 \text{ kN/m}^3$$

$$K_a = 0.35$$

$$\delta = \frac{3}{4}\phi = 22^\circ$$

$$\phi = 29^\circ$$

6.0 – Tie Down

The roof & floor structures must be secured properly to the wall framing to prevent against uplift forces & raking forces in the building. The design uplift force shall be calculated as per section 9 of AS1684.2 & 3.

The following are modified typical connections for tie down as presented in the Australian Standard AS1684. 2& 3 (2010) Residential Timber Framing. Any tie down design outside the scope of this standard is to be done in accordance with AS1170.2 Wind Actions and the relevant standard or manufacturer’s design guide for the connection materials used.

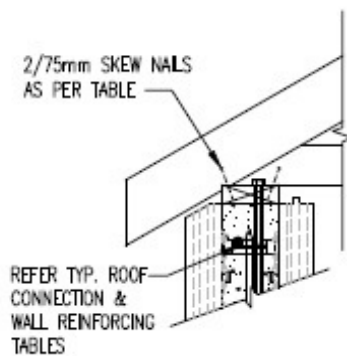

THE UPLIFT CAPACITIES GIVEN IN THIS ITEM ARE APPLICABLE TO THE JOINT NOT INDIVIDUAL NAILS.

UPLIFT CAPACITY (kN)						
UNSEASONED TIMBER			SEASONED TIMBER			
J2	J3	J4	JD4	JD5	JD6	
HAND DRIVEN NAIL DIA.						
3.15	0.97	0.82	0.71	0.51	0.34	0.24
3.75	1.1	0.97	0.87	0.66	0.40	0.29
GLUE COATED OR DEFORMED SHANK MACHINE DRIVEN NAIL DIA.						
3.05	1.5	1.2	1.1	0.77	0.50	0.36
3.33	1.7	1.5	1.3	0.99	0.60	0.43

RAFTERS/TRUSSES TO WALL FRAME OR FLOOR FRAME DETAIL 1:10

ADAPTED FROM AS1684-2010 TABLE 9.21 (d)

Fig 6a Skew Nail Connection

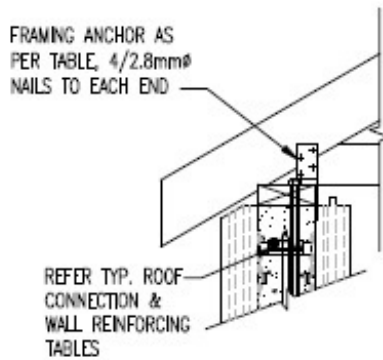

	UPLIFT CAPACITY (kN)					
	UNSEASONED TIMBER			SEASONED TIMBER		
	J2	J3	J4	JD4	JD5	JD6
	NO. OF ANCHORS					
1	4.9	3.5	2.5	3.5	2.9	2.2
2	8.3	5.9	4.2	5.9	4.9	3.7

RAFTERS/TRUSSES TO WALL FRAME OR FLOOR FRAME DETAIL 1:10

ADAPTED FROM AS1684-2010 TABLE 9.21 (b)

Fig 6b Framing Anchor Connection

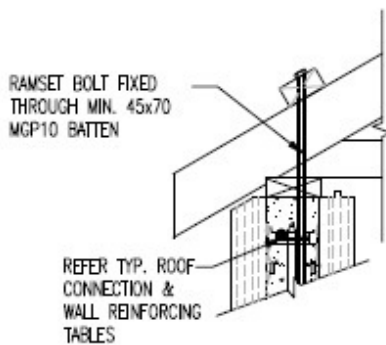

	UPLIFT CAPACITY (kN)					
	UNSEASONED TIMBER			SEASONED TIMBER		
	J2	J3	J4	JD4	JD5	JD6
1/M10	16.0	14.0	10.0	10.0	7.0	5.0

NOTE:

- BOLT TO BE MAX. 100mm AWAY FROM TRUSS OR RAFTER
- WHERE FIXING EXCEEDS 15kN, REFER TO RAMSET SPECIFIERS MANUAL FOR STRONGER ANCHOR OR USE 400 LONG CAST IN J-BOLTS WITH 90° COGGED END (50mm) IN TOP OF WALL

RAFTERS/TRUSSES TO WALL FRAME OR FLOOR FRAME DETAIL 1:10

ADAPTED FROM AS1684-2010 TABLE 9.21 (f)

Fig 6c Bolted Connection

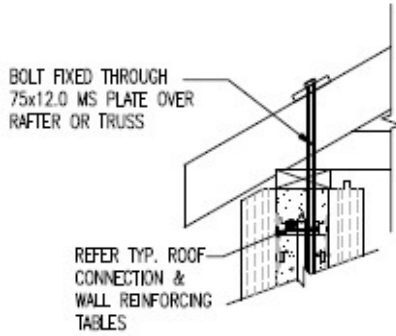

	UPLIFT CAPACITY (kN)					
	UNSEASONED TIMBER			SEASONED TIMBER		
	J2	J3	J4	JD4	JD5	JD6
2/M10	36.0	36.0	36.0	30.0	24.0	18.0
2/M12	54.0	54.0	52.0	40.0	32.0	24.0

NOTE:
 - BOLT TO BE MAX. 25mm AWAY FROM TRUSS OR RAFTER
 - WHERE FIXING EXCEEDS 15kN, REFER TO RAMSET SPECIFIERS MANUAL FOR STRONGER ANCHOR OR USE 500 LONG CAST IN J-BOLTS WITH 90° COGGED END (50mm) IN TOP OF WALL

RAFTERS/TRUSSES TO WALL FRAME OR FLOOR FRAME DETAIL 1:10

ADAPTED FROM AS1684-2010 TABLE 9.21 (h)

Fig 6d Double Bolted Connection

Where the ECO-Block wall is require for fire rating, mount the pole plate on the inside of the wall, locally removing polystyrene form for corbels at fixing points or if using 330 Series panels, remove polystyrene form after pour & bolt timber pole plate/ledger to side of wall.

6.1 – Other Roof Connections

Other connections specific to the ECO-Block insulated concrete form system are as follows.

Any connection details not covered here or previously may be found on the ECO-Block Australia website or by contacting ECO-Block Australia. Contact details at rear of manual

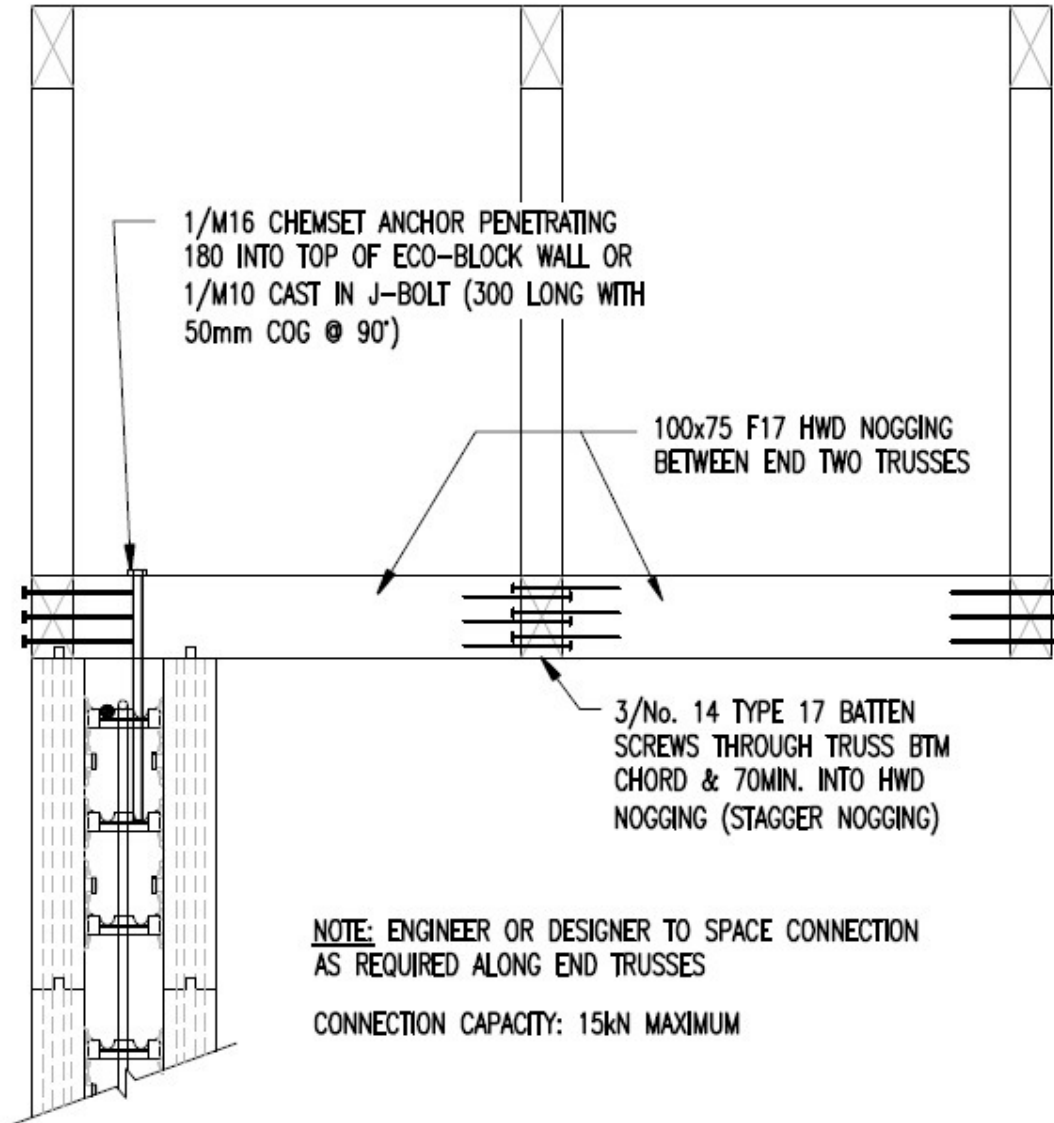

Fig 6.1a Gable End Roof over ECO-Block Wall

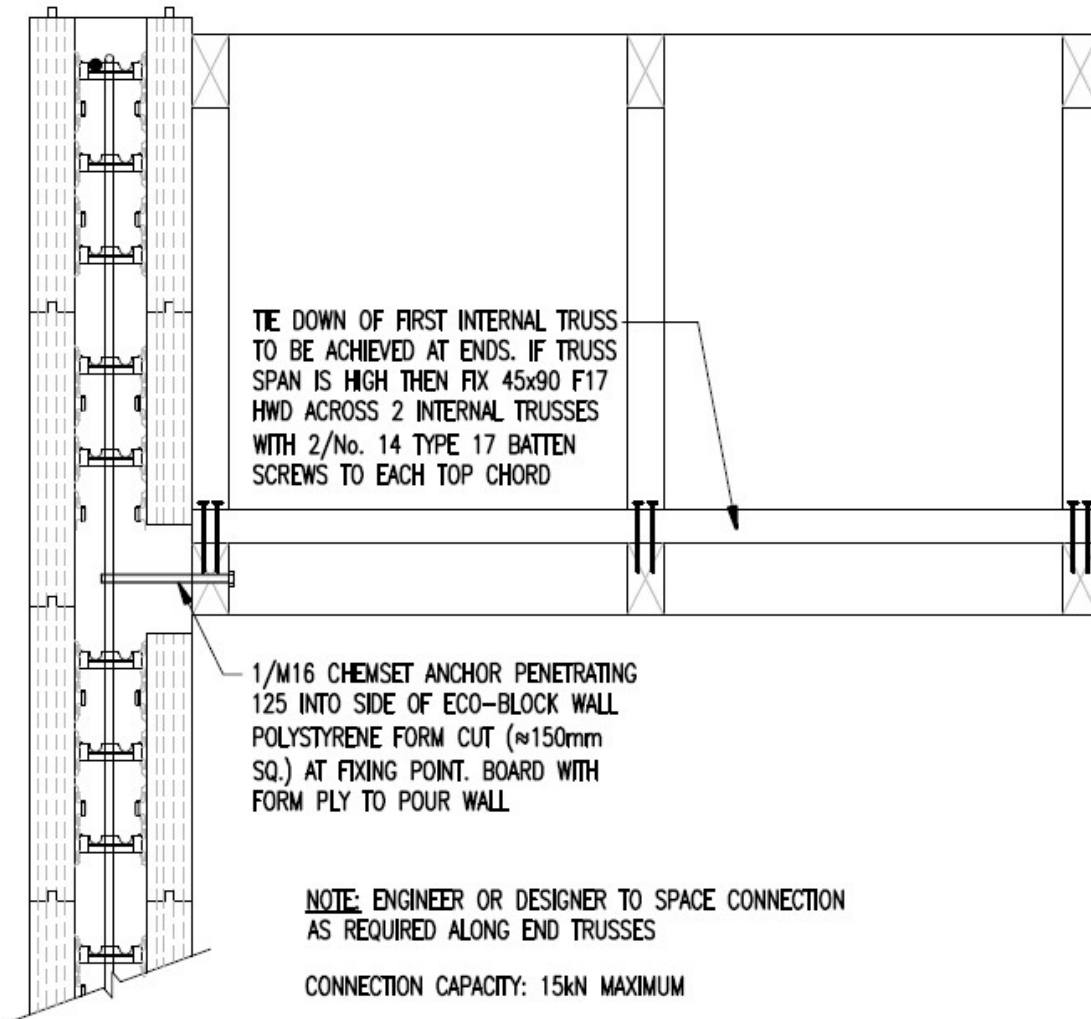

Fig 6.1b Gable End Roof with ECO-Block Wall Parapet



Simpler, Faster, Better

7.0 – Wall Finishing

The polystyrene must be enclosed for longevity and so a number of wall finishes are available for the ECO-Block product. These range from panels to applied render coats or common cladding materials such as metal sheet, hardboard & fibro-cement sheet.

7.1 – Render

There are many different types of rendering systems available for construction & residential building. It is recommended to combine the exterior face of the ECO-Block polystyrene module with a polymer render system for longevity

7.2 – Plasterboard, Hardboard & Metal Sheet

Plasterboard is the quickest and most common interior cladding. It can be screwed or fastened into the polystyrene form itself and so can be placed quickly & easily. On an open, re-entrant corner in an internal room, screws or fasteners shall be located not less 100mm from the corner of the ECO-Block. Similar types of cladding such as hardboard, FC sheet, & steel roofing or walling panels can be fastened in the same way.

7.3 – Timber Cladding

Weatherboard and shiplap timber cladding can be fastened to the polystyrene form itself & not the concrete shell. This means it is possible to retain the exterior image of a timber house but with the stronger frame and high efficiency ambient temperature control.

7.4 – Fixing of Windows

Window panels are to be fixed to ECO-Block walls in accordance with window manufacturer specifications. Concrete at window sills should be formed to create a window sill panel which falls away from the window/building. Further information, including PDF drawings of the window sill & fixings can be found on the ECO-Block Australia website.



Simpler, Faster, Better

8.0 – References

Standards Australia (2009) *AS 3600: Concrete Structures*. Sydney. www.saiglobal.com

Standards Australia (2001) *AS 3700: Masonry Structures*. Sydney. www.saiglobal.com

Standards Australia (2001) *AS 1170.0: General Principles*. Sydney. www.saiglobal.com

Standards Australia (2001) *AS 1170.1: Permanent, Imposed & Other Actions*. Sydney. www.saiglobal.com

Standards Australia (2007) *AS 1170.4: Earthquake Actions*. Sydney. www.saiglobal.com

Standards Australia (2010) *AS 1684.2: Residential Timber Framed Construction – Non Cyclonic Regions*. Sydney. www.saiglobal.com

Standards Australia (2010) *AS 1684.3: Residential Timber Framed Construction – Cyclonic Regions*. Sydney. www.saiglobal.com

Standards Australia (2006) *AS 4055: Wind Loads for Housing*. Sydney. www.saiglobal.com

Standards Australia (2002) *AS 4678: Earth Retaining Structures*. Sydney. www.saiglobal.com

ECO-Block LLC (2010). *ECO-Block Australia*. www.eco-blockaustralia.com.au



Simpler, Faster, Better

ECO BLOCK

Contact: Tony Dal Bon

Mobile: 0400301411

Phone: 1800 669 696

Email: tony@eco-blockaustralia.com.au

NEWPORT CONSULTING ENGINEERS

Contact: Matthew Yourell – Managing Director

Phone: 07 3252 9822

Email: myourell@newportengineers.com.au

Copyright & License

© Newport Consulting Engineers. All rights are reserved. A license for the unlimited use of this material is granted to Eco-Block Australia. Permission is also granted to Architects, Engineers and Builders to use this material in the preparation of specific designs, specification and contracts.